

Baureihe 43-TM - Type 43-TM

2/2 - Wege Magnetventil für Temperaturen bis +130°C

2/2 - Way Solenoid valve for temperatures up to +130°C

Standardtype

Ventil in Ruhestellung geschlossen - (NC).

Der erregte Magnet öffnet eine Vorsteuerbohrung und hebt direkt oder unterstützt von der Druckdifferenz die Membrane vom Hauptsitz. Das Ventil schließt durch Federkraft.

Standard type

Valve non-energised closed - (NC). When energised, the solenoid will open/free the pilot chamber and opens directly or supported by pressure differential the diaphragm from the valve seat. The valve closes by spring power.



Steuerungsart: Type of control:	Zwangsgesteuert Force pilot operated	Metall. Innenteile: Metallic internals:	Messing und Edelstahl 1.4104 Brass and stainless steel (AISI 430F)
Konstruktion: Construction:	Sitzventil mit Membrandichtung Diaphragm design	Dichtung: Sealing:	EPDM EPDM
Anschluß: Connection:	G1/4-G2, DIN ISO 228 G1/4-G2, DIN ISO 228	Einbaulage: Installation:	nur mit stehendem Magneten actuator only in upright position
Druck: Pressure:	0-16 bar (s. Tabelle) 0-16 bar (see table)	Anschlußspannung: Supply voltage:	AC: 24,42,110,230V 50/60Hz DC: 24,110,205V=
Durchflußmedium: Medium:	neutrale, gasförmige u. flüssige Medien neutral, gaseous and liquid media	Spannungstoleranz: Voltage tolerance:	+5% / -10% +5% / -10%
Viskosität: Viscosity:	22mm ² /s 22mm ² /s	Leistungsaufnahme: Power-consumption:	T012 = 18,5 Watt R322 = 21 Watt R242 = 44 Watt T272 = 60 Watt
Mediumtemperatur: Medium temperature:	-10 bis +130°C -10 up to +130°C	Schutzart: Protection class:	IP65 nach DIN 40050 IP65 according to DIN 40050
Umgebungstemperatur: Ambient temperature:	+35°C +35°C	Einschaltdauer: Duty factor:	100% ED-VDE 0580 100% ED-VDE 0580
Ventilgehäuse: Body material:	../10../.. = Messing / Brass ../08../.. = Edelstahl 1.4581 Stainless steel (AISI 316Ti)	Kabelanschluß: Cable connection:	Gerätestecker DIN 43650 / Klemmkasten DIN 43650 - plug / Terminal box

Die Kv-Werte in der Tabelle gelten jeweils für das größte angegebene Magnetsystem!*
In each case, the flow-rate in the table are for the biggest mentioned solenoid system!*

G	Sitz Orifice Ømm	Kv-Wert* Flow-rate m ³ /h	Standardtype Standard type PN16	max. Druck bei Magnettype max. pressure regarding solenoid type			
				T012-TM	R322-TM	R242-TM	T272-TM
1/4	13,5	1,8	D4321/..06/....	0-10	0-16*	-	-
3/8	13,5	3,6	D4322/..06/....	0-10	0-16*	-	-
1/2	13,5	3,9	D4323/..06/....	0-10	0-16*	-	-
3/4	27,5	10,8	D4324/..06/....	0-8	0-16*	-	-
1	27,5	13,0	D4325/..06/....	0-8	0-16*	-	-
5/4	40,0	22,0	B4326/..06/....	-	0-3	0-8	0-16*
6/4	40,0	25,0	B4327/..06/....	-	0-3	0-8	0-16*
2	50,0	30,0	B4328/..06/....	-	0-2	0-6	0-16*

Maßzeichnung Standardausführung
Dimensional drawing of standard type

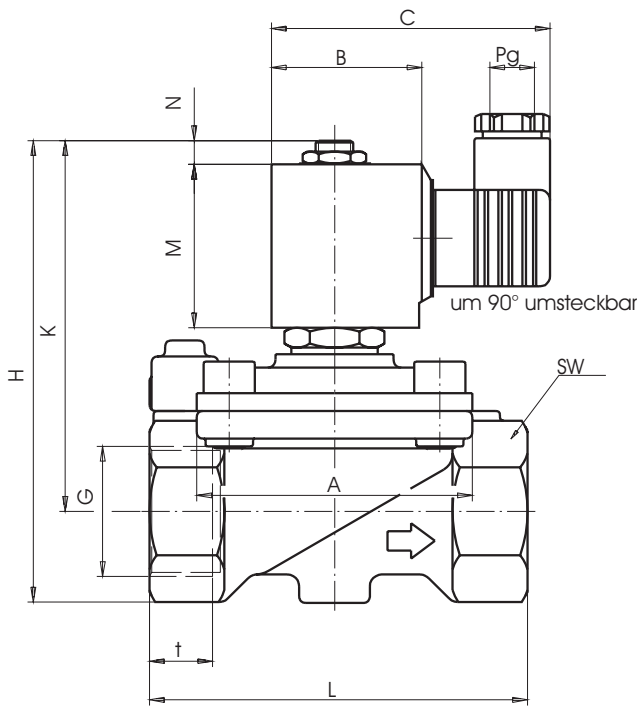

Schaltfunktion/Function:
in Ruhestellung gesperrt - NC.
normally closed - NC.

Anschlußplan / Connection diagram

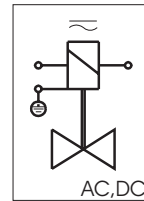

Für Wechsel- und Gleichspannung.
For AC and DC.

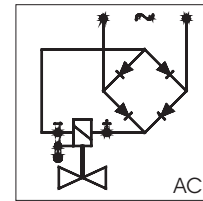

Mit vorgeschaltetem Gleichrichter
für Wechselspannung.
With rectifier for AC connection.

Erdung oder Schutzschaltung nach Vorschrift des zuständigen EVU.
Grounding or earthing of the protective circuit in accordance with regulations of the responsible electric supply company.

Absicherung entsprechend der Stromaufnahme vorsehen.
Appropriate protection according to the power-consumption.

Magnet Solenoid	T012		R322				R242		T272	
	4321-23	4324-25	4321-23	4324-25	4326-27	4328	4326-27	4328	4326-27	4328
Type	4321-23	4324-25	4321-23	4324-25	4326-27	4328	4326-27	4328	4326-27	4328
G	1/4-1/2	3/4-1	1/4-1/2	3/4-1	5/4-6/4	2	5/4-6/4	2	5/4-6/4	2
A	□45	□70	□45	□70	□96	□112	□96	□112	□96	□112
B	35x32	35x32	Ø63	Ø63	Ø63	Ø63	Ø77	Ø77	Ø105	Ø105
C	58	58	76	76	76	76	82	82	95	95
H	122	132	162	172	208	217	233	242	310	290
K	107	109	147	149	175	182	200	207	277	255
L	67	96	67	96	140	168	140	168	140	168
M	40	40	59	59	59	59	70	70	90	90
N	10	10	16	16	16	16	19	19	25	25
SW	27	41	27	41	58	70	58	70	58	70
t	12	16	12	16	22	25	22	25	22	25
Pg	11	11	11	11	11	11	13,5	13,5	13,5	13,5
kg	1,0	1,2	2,1	2,6	4,5	5,3	5,7	6,5	9,0	10,2

Ventiloptionen

Stromlos geöffnet = NO
Non energised open = NO

Dichtung = FKM
Sealing = FKM

Andere Durchflußmedien und Viskositäten
Varying medium and viscosity ranges

Stellungsanzeiger (Endschalter ab G3/4 mit Magnet .322) = EH
Position indicator (reed contact up to G3/4 with solenoid .322) = EH

Abgedichteter Ankerraum = AA
Sealed plunger = AA

/

Valve options

Handbetätigung = HA
Manual operation = HA

Regulierbare Schließdämpfung (ab G3/4) = SR
Variable close muting (from G3/4) = SR

Öl- und fettfrei = OF
Free of oil and grease = OF (for oxygen applications)

Buntmetallfrei = BF
Free of non-ferrous metal = BF

Ausführung geeignet zum Einbau mit liegenden
Magneten = MF
Mounting of the actuator in horizontal position = MF

Stückliste - Parts list

- K1.1 Armatur / Valve body
- K2.1 Deckel / Bonnet
- *K3.1 Vorsteuersitz / Pilot seat
- *K3.2 Membrane / Diaphragm
- *K3.3 Führungsstern / Guiding insert
- *K3.4 Vorsteuerspindel / Pilot spindle
- K3.6 Zylinderschraube / Cylinder screw
- *K3.7 Überwurfmutter / Union nut
- *K3.8 O-Ring / O-ring
- K3.10 Verschlussstopfen / Sealing plug
- K3.12 Scheibe / Disk
- K3.13 Dämpfungsschraube / Damping screw
- K3.15 Filteraufnahme / Filter retainer
- *K3.19 O-Ring / O-ring
- *K3.23 O-Ring / O-ring
- *K3.24 O-Ring / O-ring
- K3.25 Filtersieb / Strainer
- *K3.26 O-Ring / O-ring
- *K3.27 6-kt. Mutter / Hexagon nut
- K3.28 6-kt. Mutter / Hexagon nut
- *K3.29 6-kt. Mutter / Hexagon nut
- *K3.30 O-Ring / O-ring
- *K3.31 O-Ring / O-ring
- *K3.33 Feder / Spring
- K5.1 Magnethülse / Solenoid tube
- *K5.2 Magnetanker / Solenoid plunger
- *K5.3 Ankerfeder / Plunger spring
- K5.4 Druckstück / Pressure piece
- K5.5 O-Ring / O-ring
- K5.6 Scheibe / Disk
- K5.7 Zylinderschraube / Cylinder screw
- K5.8 6-kt. Mutter / Hexagon nut
- K5.9 Wellscheibe / Corrugated disk
- K6.1 Magnet / Solenoid
- K7.1 Gerätestecker / Plug

* = Bestandteil des Ersatzteilkäppchens
(je nach Ausführung freibleibend)
* = Part of the spare parts set.
(These specifications are without obligation).

Regulierbare Schließdämpfung - SR (von G5/4-G2 (serienmäßig)
Device for adjustable close damping - SR
(From G5/4-G2 standard)

Schraube nach rechts drehen : Ventil schließt langsamer
Screw to the right site : Valve closes slower
Schraube nach links drehen : Ventil schließt schneller
Screw to the left site : Valve closes faster

Ansicht/View A

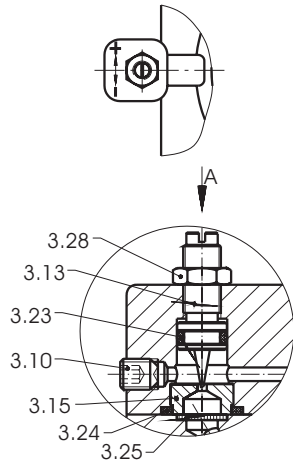

Baureihe / Type D4321-D4323

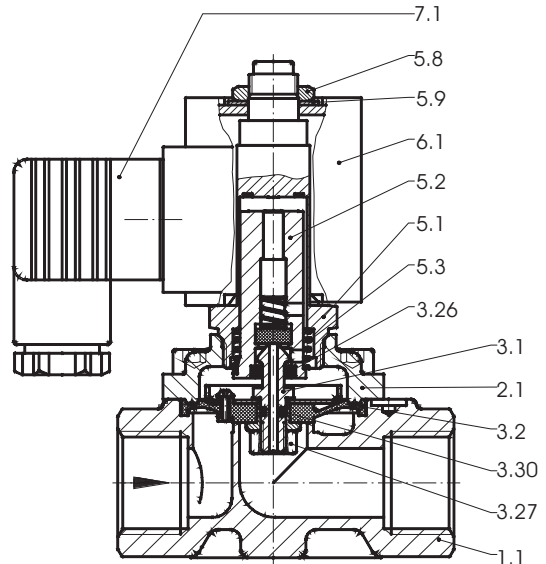

Baureihe / Type D4324 / D4325

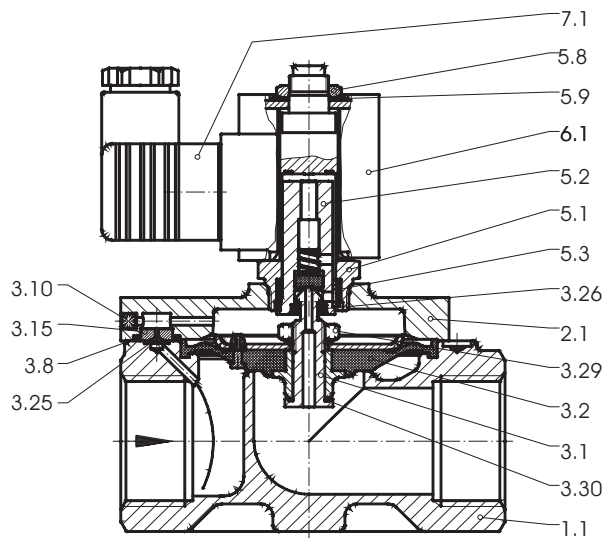

Baureihe / Type B4326 - B4328

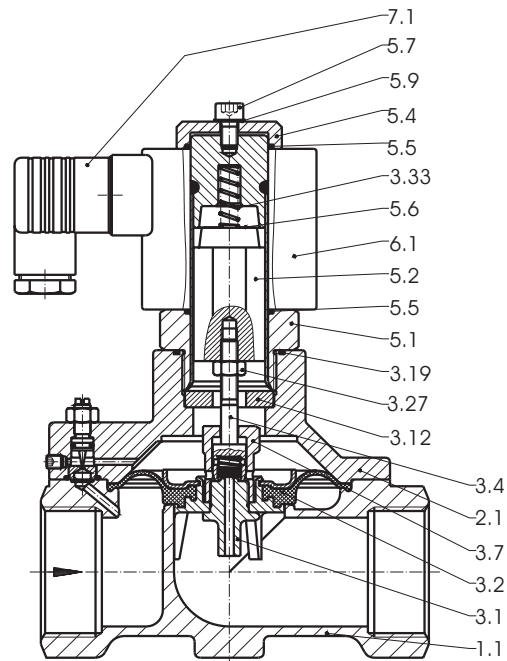

Ventiloptionen / Valve options

Handbetätigung - HA
Manual operation - HA

- K3.61 Zwischenverschraubung / Screw joint
- K3.62 Spindel / Spindle
- K3.63 Verschraubung / Screw joint
- K3.64 Scheibe / Disk
- K3.65 Nutring / U-cup seal
- K3.66 O-Ring / O-ring
- K3.67 Handrad / Handwheel
- K3.68 Zylinderschraube / Cylinder screw

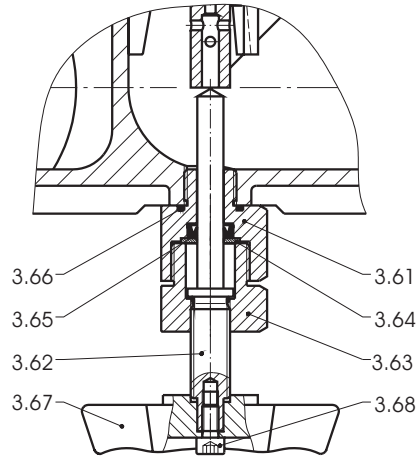

Stellungsanzeiger - EH (ab G3/4 mit Magnet / .322)
Position indicator - EH (from G3/4 with solenoid / .322)

- K3.33 Feder / Spring
- K3.75 Zwischenverschraubung / Screw joint
- K3.76 Spindel / Spindle
- K3.77 Befestigungsmutter / Locking nut
- K3.79 O-Ring / O-ring
- K3.82 Senkschraube / Screw
- K3.83 Permanentmagnet / Permanent magnet
- K3.84 Klemmring / Clamping ring
- K3.85 Verschraubung / Screw joint
- K3.86 Endschalter / Position indicator
- K3.87 Scheibe / Disk
- K5.1 Magnethülse / Solenoid tube
- K5.2 Magnetanker / Solenoid plunger
- K5.5 O-Ring / O-ring
- K5.6 Scheibe / Disk
- K6.1 Magnet / Solenoid

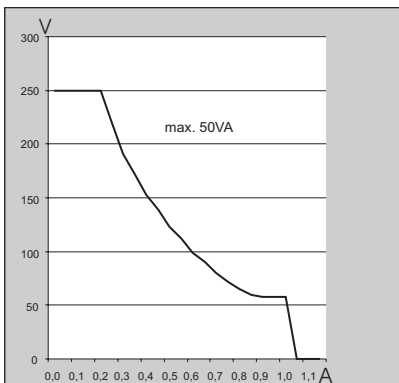
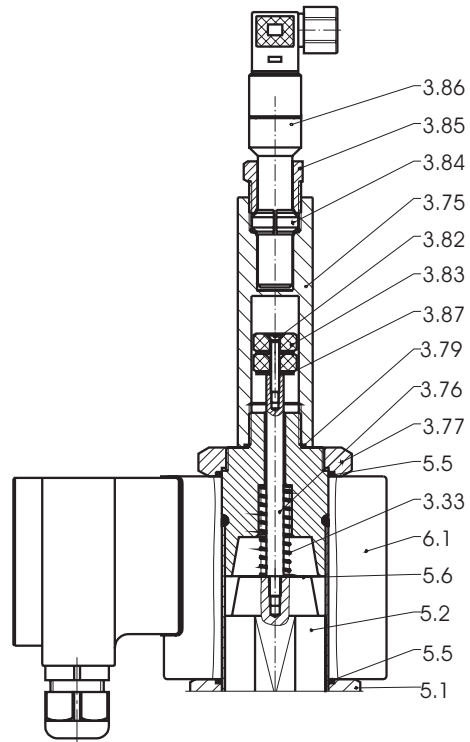

Schaltleistungsdiagramm
Braking capacity diagram

Anschlußplan
Connection plan
Endschalter / Position indicator

