

Baureihe 49 - Type 49

2/2- Wege Magnetventil

2/2- Way Solenoid valve

Standardtype

Ventil in Ruhestellung geschlossen-NC. Der erregte Magnet öffnet eine Vorsteuerbohrung und hebt direkt oder unterstützt von der Druckdifferenz den Kolben vom Hauptsitz. Das Ventil schließt durch Federkraft.

Standard type

Valve normally closed - NC. When energised, the solenoid will open/free the pilot chamber and the valve will open directly or servo assisted by the pressure differential of the flow medium. The valve closes by spring power.



Steuerungsart: Type of control:	Zwangsgesteuert Force pilot operated	Metall. Innenteile: Metallic internals:	Messing und Edelstahl 1.4104 Brass and stainless steel (AISI 430F)
Konstruktion: Construction:	Kolbensitzventil Piston design	Dichtung: Sealing:	NBR NBR
Anschluß: Connection:	G1/4-G3, DIN ISO 228 G1/4-G3, DIN ISO 228	Einbaulage: Installation:	nur mit stehendem Magneten actuator only in upright position
Druck: Pressure:	0-40 bar (s. Tabelle) 0-40 bar (see table)	Anschlußspannung: Supply voltage:	AC: 24,42,110,230V 50Hz DC: 24,110,205V=
Durchflußmedium: Medium:	neutrale, gasförmige u. flüssige Medien neutral, gaseous and liquid medium	Spannungstoleranz: Voltage tolerance:	+5% / -10% +5% / -10%
Viskosität: Viscosity:	22mm ² /s 22mm ² /s	Leistungsaufnahme: Power-consumption:	1702/3702 = 25 Watt 1322/3322 = 30 Watt 4242/5242 = 46 Watt 4272/5272 = 100 Watt
Mediumtemperatur: Medium temperature:	-10 bis +80°C -10 up to +80°C	Schutzart: Protection class:	IP65 nach DIN 40050 IP65 according to DIN 40050
Umgebungstemperatur: Ambient temperature:	+35°C +35°C	Einschaltdauer: Duty factor:	100% ED-VDE 0580 100% ED-VDE 0580
Ventilgehäuse: Body material:	../10/.. = Messing / Brass ../08/.. = Edelstahl 1.4581 / St. steel (AISI 316Ti)	Kabelanschluß: Cable connection:	Gerätestecker DIN 43650 / Klemmkasten DIN 43650 - Plug / terminal box

Die Kv-Werte in der Tabelle gelten jeweils für das größte angegebene Magnetsystem!*
In each case, the flow-rate in the table are for the biggest mentioned solenoid system!*

G	Sitz Orifice mm	Kv-Wert Flow-rate m ³ /h	Standardtype Standard type PN40	max. Druck bei Magnettype max. pressure regarding solenoid type			
				.702	.322	.242	.272
1/4	13	1,8	F4921/1001/....	0-25	0-40*	-	-
3/8	13	4,0	F4922/1001/....	0-25	0-40*	-	-
1/2	13	4,5	F4923/1001/....	0-25	0-40*	-	-
3/4	25	11,5	F4924/1001/....	-	0-25	0-40*	-
1	25	13,0	F4925/1001/....	-	0-40	0-40*	-
5/4	40	29,0	B4926/1001/....	-	-	0-25	0-40*
6/4	40	33,0	B4927/1001/....	-	-	0-25	0-40*
2	50	49,0	B4928/1001/....	-	-	0-25	0-40*
2½	63	75,0	B4929/1001/....	-	-	0-10*	-
3	76	97,0	B4930/1001/....	-	-	0-10*	-

Maßzeichnung Standardausführung
Dimensional drawing of standard type

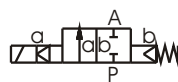
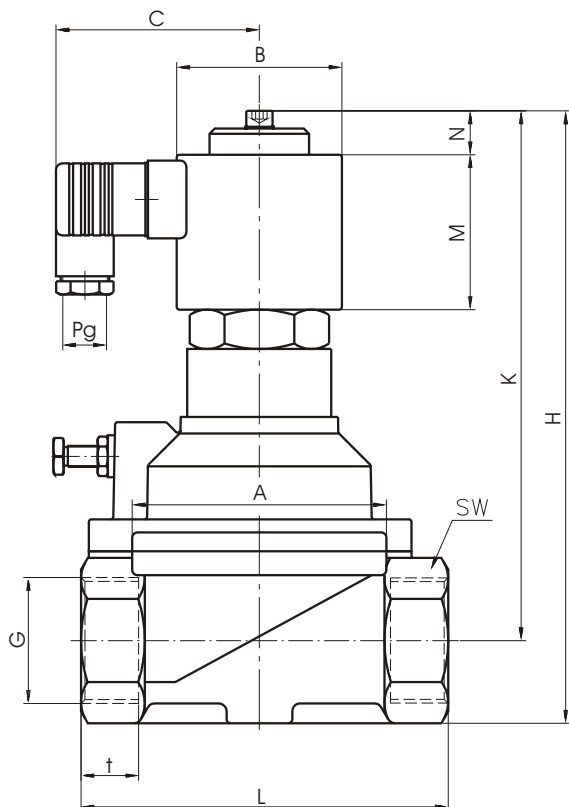

Schaltfunktion/Function:
in Ruhestellung gesperrt - NC.
normally closed - NC.

Anschlußplan / Connection diagram

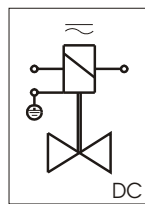

Für Gleichspannung.
For DC.

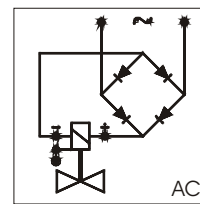

Mit vorgeschaltetem Gleichrichter
für Wechselspannung.
With rectifier for AC connection.

Erdung oder Schutzschaltung nach Vorschrift des zuständigen EVU.
Grounding or earthing of the protective circuit in accordance
with regulations of the responsible electric supply company.

Absicherung entsprechend der Stromaufnahme vorsehen.
Appropriate protection according to the power-consumption.

Magnet Solenoid	.702		.322		.242				.272		
Type	4921-4923	4921-4923	4924-4925	4926-4927	4924-4925	4926-4927	4928	4929	4930	4926-4927	4928
G	1/4-1/2	1/4-1/2	3/4-1	5/4-6/4	3/4-1	5/4-6/4	2	2½	3	5/4-6/4	2
A	50	50	70	96	70	96	112	90	105	96	112
B	35x35	63	63	63	77	77	77	77	77	105	105
C	66	76	76	76	82	82	82	82	82	95	95
H	173	200	200	238	225	263	275	275	292	310	290
K	158	185	175	205	200	230	240	205	212	277	255
L	67	67	96	140	96	140	168	175	200	140	168
M	50	59	59	59	70	70	70	70	70	90	90
N	10	16	16	16	20	20	20	20	25	25	25
SW	27	27	41	58	41	58	70	86	100	58	70
t	12	12	16	22	16	22	25	18	20	22	25
Pg	11	11	11	11	11	11	11	11	11	11	11
kg	0,7	1,5	3,5	6,8	4,2	7,5	8,6	9,2	9,5	9,9	11

Ventiloptionen

Stromlos geöffnet = NO
Non energised open = NO

Dichtung = FKM, EPDM, PTFE
Sealing = FKM, EPDM, PTFE

Andere Durchflußmedien und Viskositäten
Varying medium and viscosity ranges

Ventilgehäuse = Rotguß
Body material = Red brass

Stellungsanzeiger (Endschalter ab G3/4 mit Magnet /.322) = EH
Position indicator (reed contact from G3/4 with solenoid /.322) = EH

Ex-Schutz = Ex II 2G EEx em II T4
Explosion proof = Ex II 2G EEx em II T4

Weitere Ex-Schutzarten auf Anfrage
Further Ex-plosion proof protection classes on demand

/

Valve options

Handbetätigung = HA
Manual operation = HA

Regulierbare Schließdämpfung = SR (ab G3/4 bis G2)
Device for adjustable close damping =
SR (from G3/4 up to G2)

Öl- und fettfrei = OF
Free of oil and grease = OF (for oxygen applications)

Temperaturlösung bis 180°C = TH
Design for high temperature up to 180°C = TH

Grundmengeneinstellung = GM
Adjusting of basic amount = GM

NPT-Anschlußgewinde = NG
NPT-connection = NG

Stückliste - Parts list

- K1.1 Armatur / Valve body
- K2.1 Deckel / Bonnet
- *K3.1 Vorsteuersitz / Pilot seat
- *K3.2 Ventilkolben komplett / Complete valve piston
- *K3.3 Führungsstern / Guiding insert
- K3.4 Vorsteuerspindel / Pilot spindle
- *K3.7 Überwurfmutter / Union nut
- *K3.8 Kolben / Piston
- K3.11 Zwischenverschraubung / Screw joint
- K3.13 Dämpfungsschraube / Damping screw
- K3.14 Scheibe / Disk
- K3.15 Kolbenführungsband / Piston guide band
- *K3.16 Nutring / U-ring
- *K3.17 Führungsband / Piston ring
- *K3.18 O-Ring / O-ring
- *K3.19 O-Ring / O-ring
- *K3.20 O-Ring / O-ring
- *K3.21 O-Ring / O-ring
- *K3.22 O-Ring / O-ring
- *K3.23 O-Ring / O-ring
- K3.24 O-Ring / O-ring
- K3.27 6-kt. Mutter / Hexagon nut
- K3.28 6-kt. Mutter / Hexagon nut
- *K3.33 Feder / Spring
- K5.1 Magnethülse / Solenoid tube
- K5.2 Magnetanker / Solenoid plunger
- K5.4 Druckstück / Pressure piece
- K5.5 O-Ring / O-ring
- K5.6 Scheibe / Disk
- K5.8 Zylinderschraube / Cylinder screw
- K5.9 Scheibe / Disk
- K6.1 Magnetspule / Solenoid
- K7.1 Stecker oder Klemmkasten / Plug or terminal box

* = Bestandteil des Ersatzteilkäppchens
(je nach Ausführung freibleibend)
* = Part of the service-set (these specifications
are without obligation).

Regulierbare Schließdämpfung - SR (von G5/4-G2 serienmäßig)
Device for adjustable close damping - SR (from G5/4-G2 standard)

Schraube nach rechts drehen : Ventil schließt langsamer
Screw to the right site : Valve closes- slower
Schraube nach links drehen : Ventil schließt schneller
Screw to the left site : Valve closes - faster

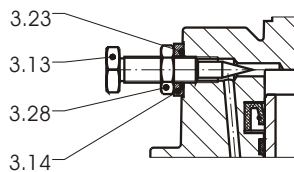

Baureihe / Type 4921-4925

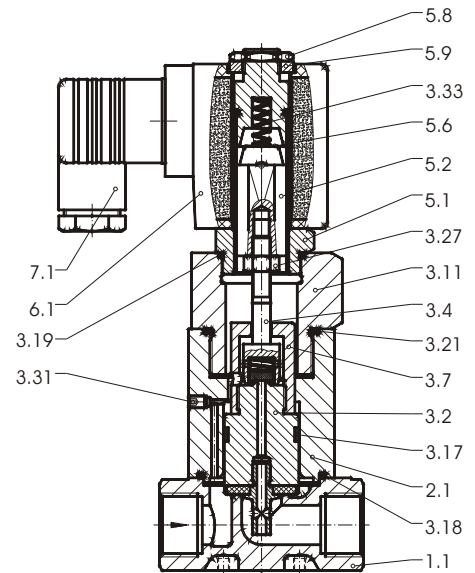

Baureihe / Type 4926-4928

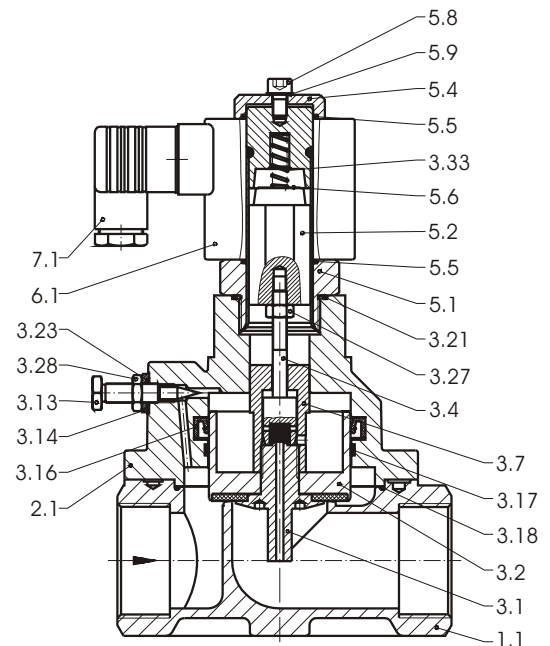

Baureihe / Type 4929-4930

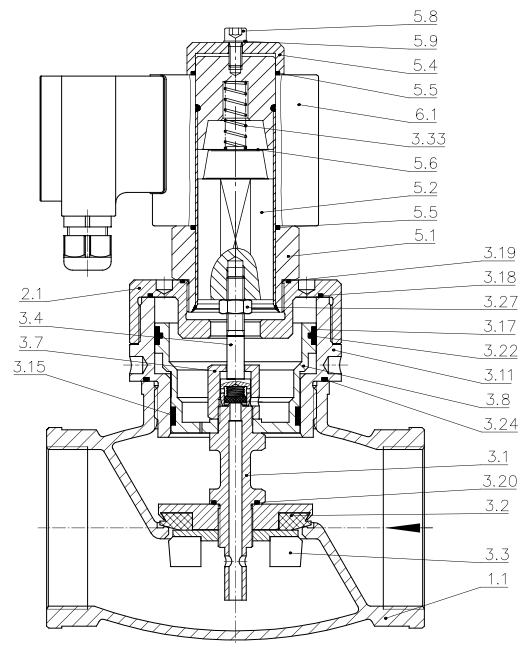

Ventiloptionen / Valve options

Handbetätigung - HA
Manual operation - HA

- K3.61 Zwischenverschraubung / Screw joint
- K3.62 Spindel / Spindle
- K3.63 Verschraubung / Screw joint
- K3.64 Scheibe / Disk
- K3.65 Nutring / U-ring
- K3.66 O-Ring / O-ring
- K3.67 Handrad / Handwheel
- K3.68 Zyl.-schraube / Cylinder screw
- K3.69 Scheibe / Disk

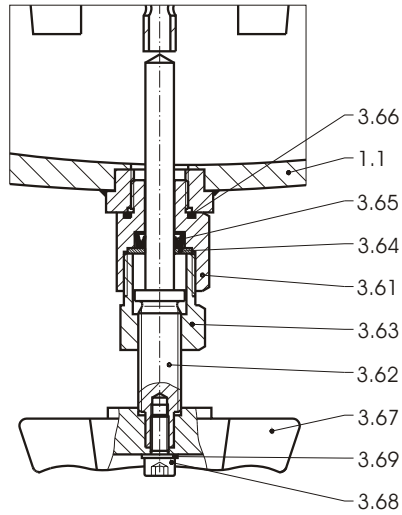

Stellungsanzeiger - EH (ab G1/4 mit Magnet / .322)
Position indicator - EH (from G1/4 with solenoid / .322)

- K3.75 Zwischenverschraubung / Screw joint
- K3.76 Spindel / Spindle
- K3.77 Schutzrohr / Protection tube
- K3.79 O-Ring / O-ring
- K3.82 Senkschraube / Countersunk bolt
- K3.83 Permanentmagnet / Permanent magnet
- K3.84 Klemmring / Clamp ring
- K3.85 Verschraubung / Screw joint
- K3.86 Endschatler / Position indicator
- K3.87 6-kt. Mutter / Hexagon nut

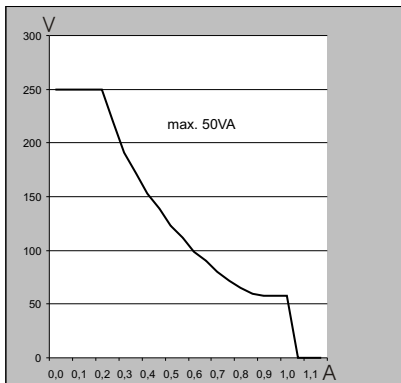
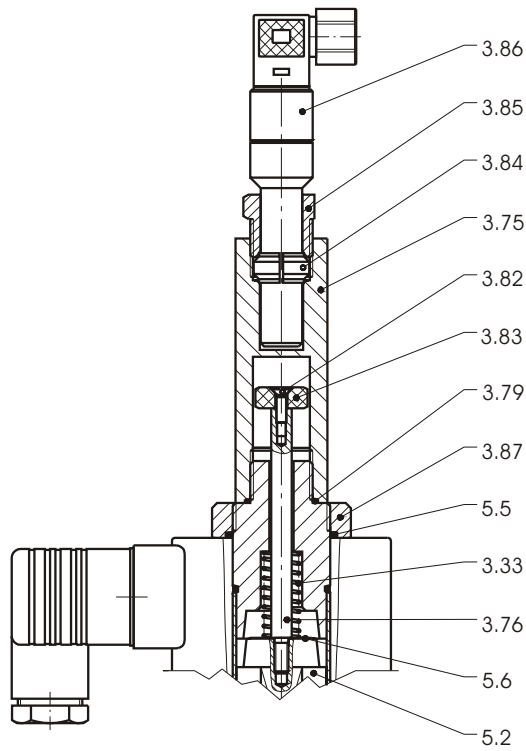

Schaltleistungsdiagramm
Braking capacity diagram

Anschlußplan /
Connection diagram

Endschalter / Position indicator

