

Aluminium Roller Guides

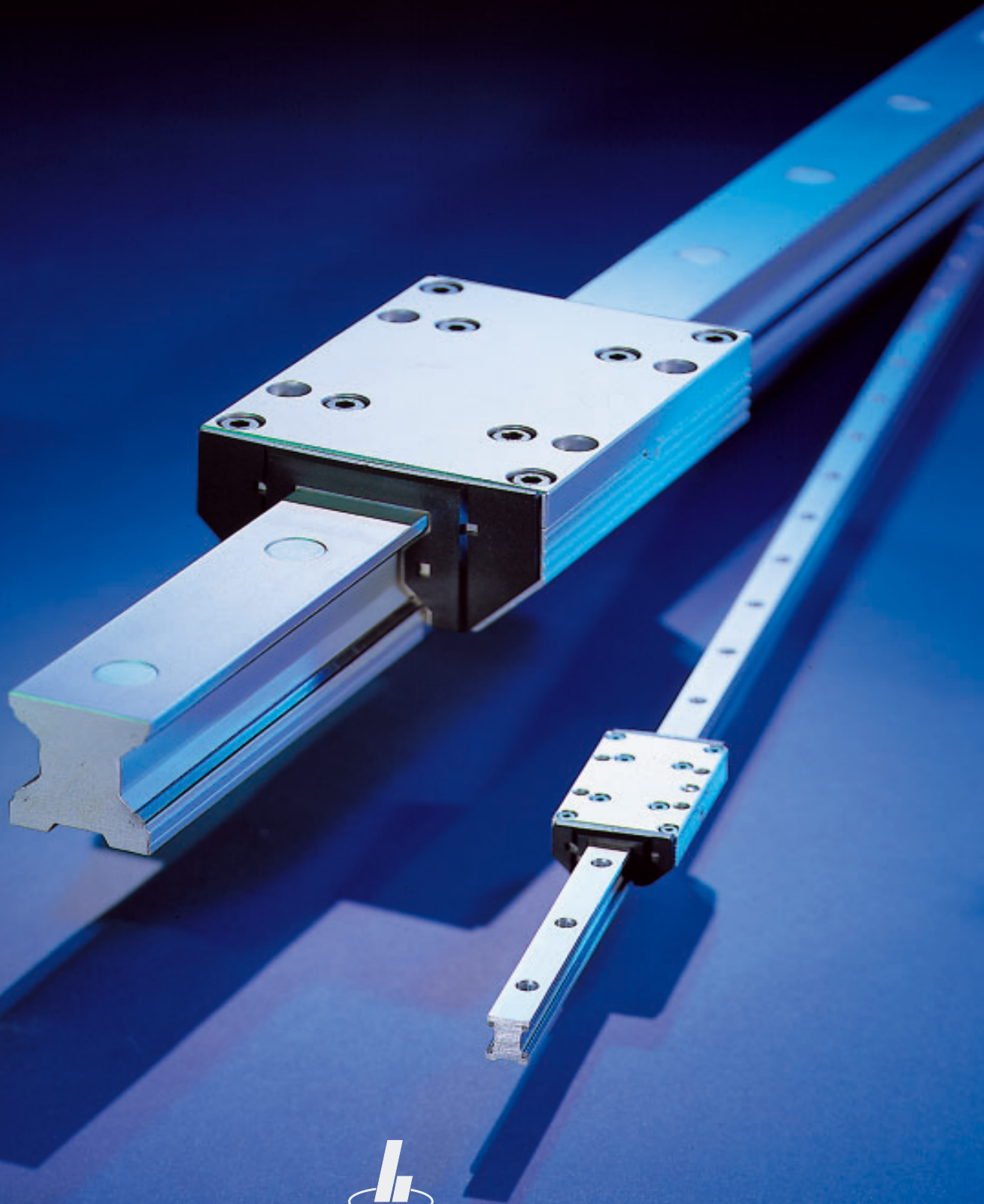

HOERBIGER

ORIGA

Aluminium-Rollenführungen

The characteristics of HOERBIGER-ORIGA aluminium roller guides are very high performance and low weight. They are quiet and precise in operation.

Application

Aluminium roller guides provide smooth operation and high load carrying capacity for industrial automation.

By the use of lightweight aluminium components the moving masses are minimised, travel speeds are increased and actuation energy is saved.

Their smooth action and speeds up to 10 m/s make them ideal for widespread use in many areas of application.

Product

- Light weight (aluminium)
- Smooth operation
- Speeds up to 10 m/s
- Loading from any direction
- Virtually grease-free guidance system
- Flexible mounting dimensions
- High load capability

Designs

- Double rail
 - Single rail
- available in a standard version, a rustproof version and a LOW COST version

Technical data

- Sizes 12, 15, 20, 25, 35 and 45
 - Rail lengths 300 mm to 4000 mm (other lengths on request).
- For longer travel the guide rails can be joined together.

See technical section for further technical details.

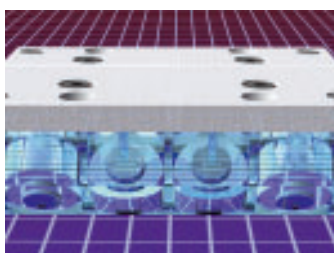

Rollers of standard roller cassette



Rail profiles and roller cassettes made of aluminium

Ground and calibrated tracks

Application examples

Aluminium roller guides in a cutting machine for spectacle lenses. Both the work piece carriers and the motorised X - Y table axis are equipped with roller guides.

The smooth operation and precision of the equipment ensures a fine cutting action. (Kasch company photo)



Aluminium roller guides in an automatic vibrator for flattening printed sheets of paper. To guarantee even pressure on the sheets of paper, the roller bridge is supported by precision roller guides.

(Baumann company photo)



Handling units for medical equipment. Smooth, easy movement with guideline roller guide. (Dräger company photo)



Aluminium roller guides in the sliding carriage of a machine for producing cables. The projecting arm of the carriage is guided by two double rails each with two roller cassettes and can be moved manually with minimal force because of the low friction properties.

(Kabelmat company photo)



Single rail and roller shoe versions of the aluminium roller guide in a handling arrangement for stacks of paper. Various fittings and limit stops for stacking are moved on two axes horizontally and vertically.

The robustness and reliability of the roller guides allows for continuous operation under high load conditions. (Solms company photo)

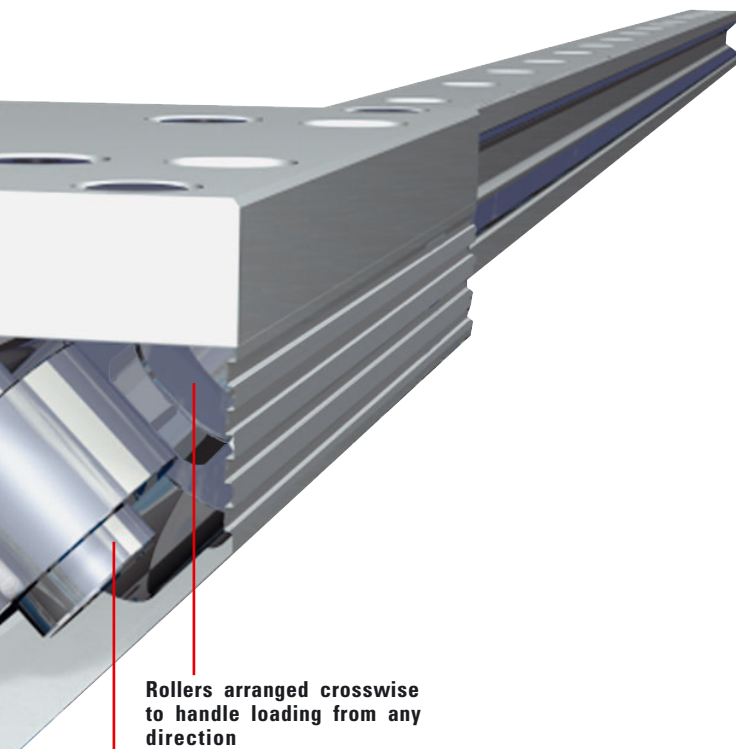

Rollers arranged crosswise to handle loading from any direction

Rollers on needle bearings for smooth operation at speeds up to 10 m/s

Characteristics for Double Rail GDL-FD and Single Rail GDL-FE

Characteristics

Characteristic	Unit	Description
Sealing		The roller shoe and cassettes are fitted with felt wiper rings, in a clip-on housing. See page 8 for spare wipers
Mounting		Rails and roller shoes with screw-quality 8.8, washer to DIN 433
Loads		See load data in the table. We are happy to calculate loads and service life for you on request
Acceleration, Deceleration	m/s ²	max. 40
Installation		In any position
Adjustment		The roller shoes can be adjusted/readjusted by the customer
Lengths		L = 300 mm to 4000 mm, (in double rail standard version sizes 25 and 35 also in 6000 mm) – For the stainless steel version size 15 L 300 mm to 3000 mm – Other lengths on request – For longer travel the guide rails can be joined together
Lubrication		Lifetime lubrication with roller bearing grease
Speed	m/s	up to 10
Materials – Standard version		Rails: Aluminium, anodized Tracks: High alloy spring steel Roller cassettes: Aluminium, anodized Rollers: Roller bearing steel
Materials – Stainless steel version		Rails: Aluminium, anodized Tracks: Stainless spring steel Roller cassettes: Aluminium, anodized Rollers: Stainless roller bearing steel
Operating temperature	°C	-10 to +80

Double Rails GDL-FD and Roller Cassettes RK-FD



Loads, Moments and Weights

*) Recommended safety factors: Condition – Screw 8.8
 Compression load – S>1.2
 Tensile load – S>2.5
 Torque load – S>4.0

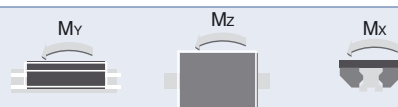

Size	Version	Load C [N]	Co [N]	M _y / M _z [Nm] *		M _x [Nm] *		Weight (Mass) [kg]	
				stat.	dyn.	stat.	dyn.	Cassette	Double rail / m
12	Standard	2800	3000	43	40	27	25	0.1	0.4
	Stainless	–	–	–	–	–	–	–	–
15	Standard	4200	3400	58	72	37	45	0.3	0.8
	Stainless	1800	2200	37	30	23	19	0.3	0.8
20	Standard	5400	5400	111	111	76	76	0.4	0.9
	Stainless	2000	2500	52	41	35	28	0.4	0.9
25	Standard	9000	10100	222	198	158	142	0.6	1.8
	Stainless	3400	4700	105	75	75	53	0.6	1.8
35	Standard	12500	18000	559	388	423	294	1.5	3.2
	Stainless	5600	7400	229	174	173	131	1.5	3.2
45	Standard	21200	25900	983	806	827	678	2.9	5.5
	Stainless	13100	16500	626	500	526	420	2.9	5.5
12	Low Cost	620	170	2.4	8.9	1.6	5.7	0.1	0.4
15	Low Cost	700	230	4	12	2.5	7.5	0.3	0.8
20	Low Cost	940	300	6	19	4	13	0.4	0.9
25	Low Cost	1500	700	15	32	11	23	0.6	1.8
35	Low Cost	3100	1400	42	95	32	72	1.5	3.2
45	Low Cost	6300	2700	103	238	86	200	2.9	5.5

Double Rails GDL-FD and Roller Cassettes RK-FD

Dimensions (mm)

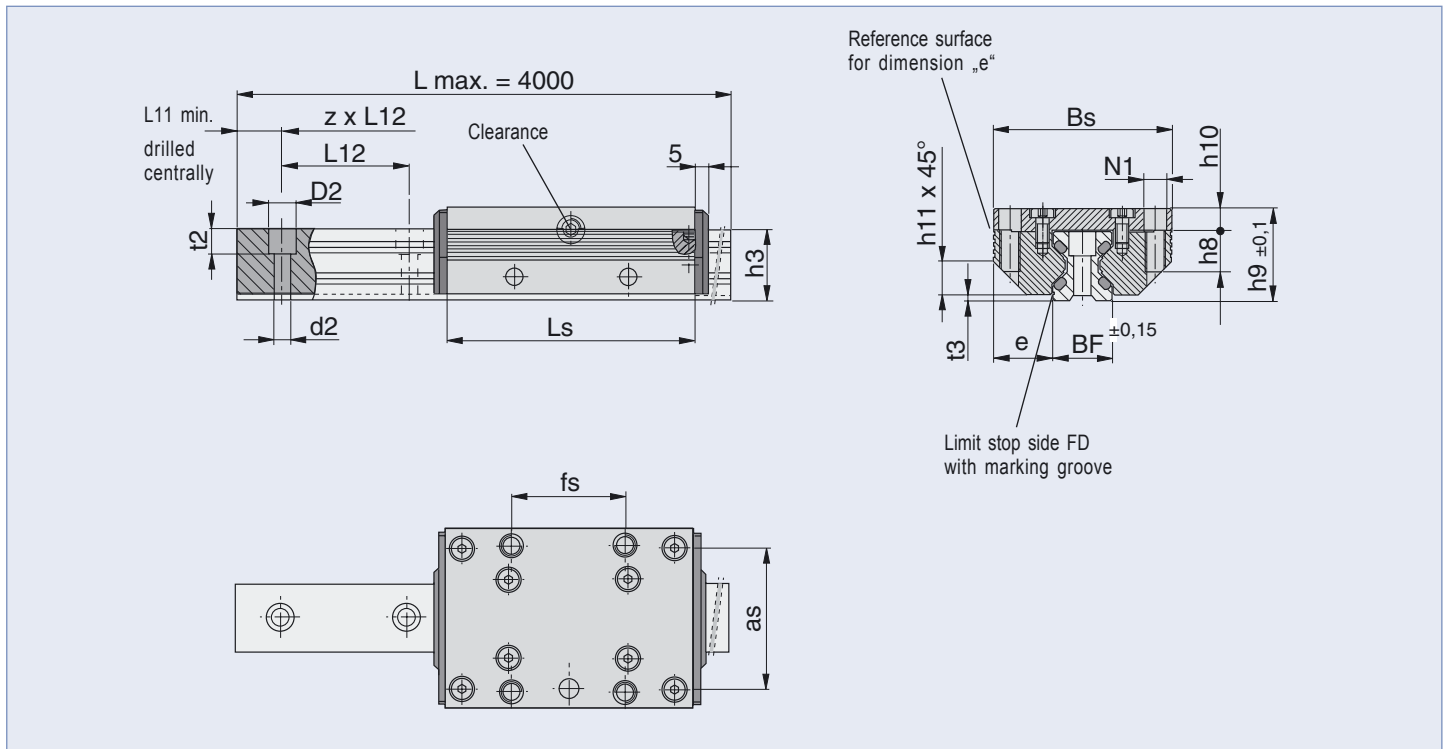

Dimension Table (mm)

Size	Ls	BF	Bs	h3	h9	as	fs	d2	D2	e	h8	h10	h11	L11	L12	t2	t3	N1
12	64	12	37	14.7	19	30	25	3.4	6	12.50	8	4.0	6	min.10	40	5.5	1.4	M4
15	78	15.5	47	18.7	24	38	30	4.5	8	15.75	10	5.0	8	min.10	60	6	2.0	M5
20	92	21.0	63	22.6	30	53	40	5.5	10	21.00	12	7.0	11	min.10	60	7	2.0	M6
25	98	23.0	70	27.0	36	57	45	6.6	11	23.50	16	8.5	13	min.10	60	10	2.5	M8
35	135	32.0	100	37.0	48	82	62	9.0	15	34.00	20	10.5	20	min.12	80	11.5	3.5	M10
45	165	45.0	120	46.0	60	100	80	11.0	18	37.50	24	13.5	22	min.16	105	14.5	4.0	M12

Order Instructions

Size	Version	Order-No.	
		Double rail GDL-FD	Cassette RK-FD
12	Standard	20929	20931
	Stainless	-	-
15	Standard	20506	20518
	Stainless	20897	20882
20	Standard	20507	20519
	Stainless	20898	20883
25	Standard	20508	20520
	Stainless	20899	20884
35	Standard	20829	20837
	Stainless	20900	20885
45	Standard	20830	20838
	Stainless	20901	20886
12	Low Cost	-	20993
15	Low Cost	-	20521
20	Low Cost	-	20522
25	Low Cost	-	20523
35	Low Cost	-	20839
45	Low Cost	-	20840

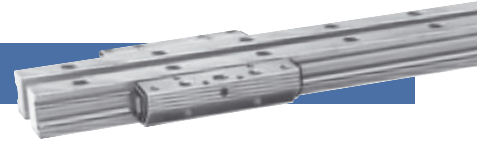

Pair of Single Rail GDL-FE and Pair of Roller Shoes RS-FE

Loads, Moments and Weights

*) Recommended safety factors: Condition – Screw 8.8
 Compression load – $S > 1.2$
 Tensile load – $S > 2.5$
 Torque load – $S > 4.0$



Size	Version	Load C [N]	Co [N]	M_y / M_z [Nm] *		M_x [Nm] *		Weight (Mass) [kg]	
				stat.	dyn.	stat.	dyn.	Pair Roller-shoes	Single Rail pair / m
12	Standard	2800	3000	43	40	1.5 (B+30.3)	1.4 (B+30.3)	0.06	0.8
	Stainless	–	–	–	–	–	–	–	–
15	Standard	4200	3400	58	72	1.7 (B+36.5)	2.1 (B+36.5)	0.2	1.6
	Stainless	1800	2200	37	30	1.1 (B+36.5)	0.9 (B+36.5)	0.2	1.6
20	Standard	5400	5400	111	111	2.72 (B+47)	2.7 (B+47)	0.3	2.0
	Stainless	2000	2500	52	41	1.3 (B+47)	1.0 (B+47)	0.3	2.0
25	Standard	9000	10100	222	198	5.0 (B+58.4)	4.5 (B+58.4)	0.5	3.8
	Stainless	3400	4700	105	76	2.4 (B+58.4)	1.7 (B+58.4)	0.5	3.8
35	Standard	12500	18000	559	388	9.0 (B+85)	6.3 (B+85)	1.4	7.0
	Stainless	5600	7400	229	174	3.7 (B+85)	2.8 (B+85)	1.4	7.0
45	Standard	21200	25900	983	806	12.9 (B+109)	10.6 (B+109)	2.8	11.2
	Stainless	13100	16500	626	500	8.2 (B+109)	6.6 (B+109)	2.8	11.2
12	Low Cost	620	170	2.4	8.9	0.08 (B+30.3)	0.3 (B+30.3)	0.06	0.8
15	Low Cost	700	230	4	12	0.1 (B+36.5)	0.35 (B+36.5)	0.2	1.6
20	Low Cost	940	300	6	19	0.15 (B+47)	0.5 (B+47)	0.3	2.0
25	Low Cost	1500	700	15	32	0.35 (B+58.4)	0.7 (B+58.4)	0.5	3.8
35	Low Cost	3100	1400	42	95	0.7 (B+85)	1.5 (B+85)	1.4	7.0
45	Low Cost	6300	2700	103	238	1.4 (B+109)	3.1 (B+109)	2.8	11.2

Dimensions (mm)

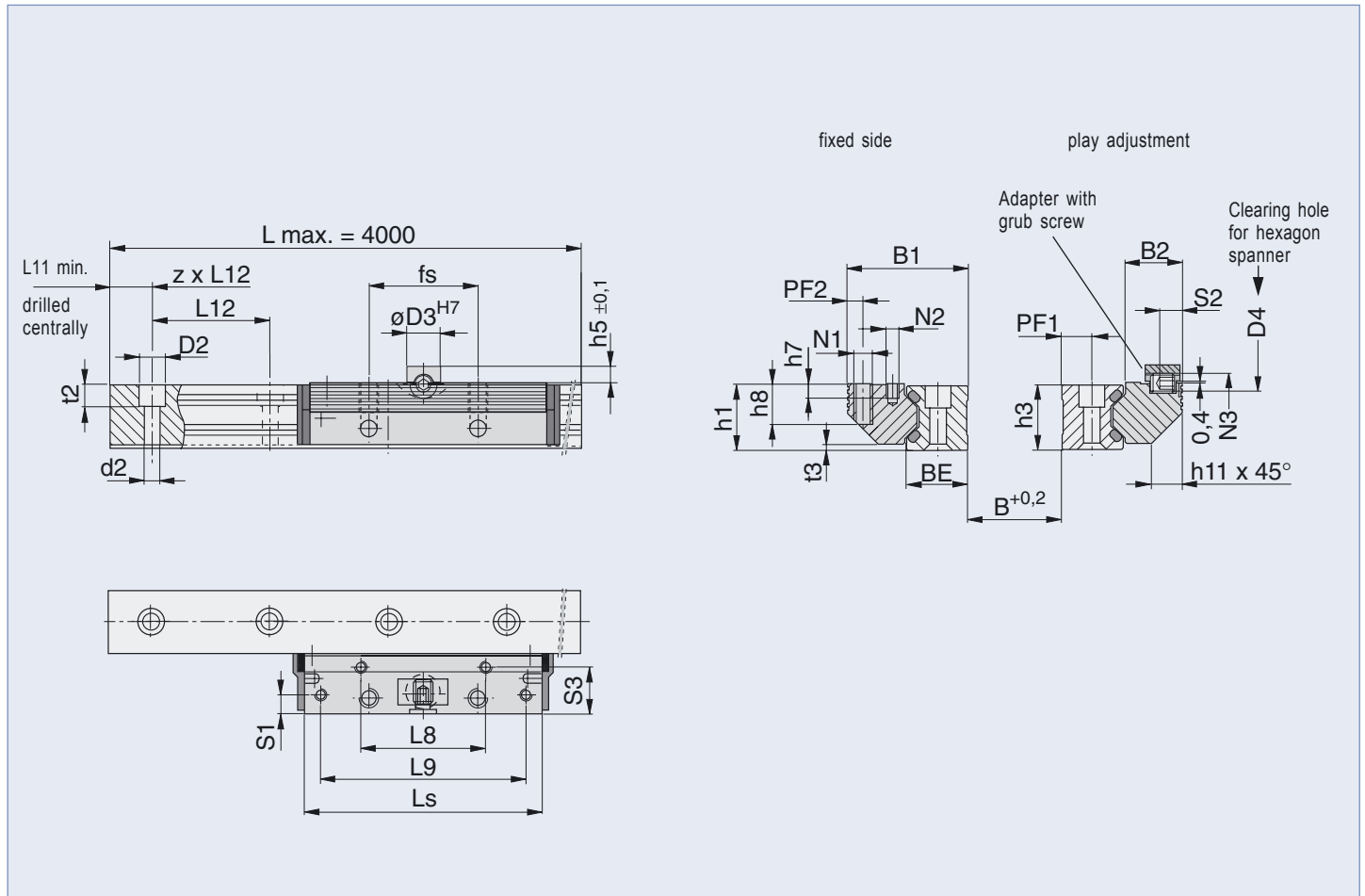

Pair of Single Rail GDL-FE and Pair of Roller Shoes RS-FE

Dimension Table (mm)

Size	Ls	BE	B1	B2	d2	D2	D3 ^{H7}	D4	fs	h1	h3	h5	h7	h8
12	64	12.00	24.5	11.9	3.4	6	8	3	25	15.0	14.7	4	6.0	8
15	78	15.25	30.9	15.2	4.5	8	10	4	30	19.0	18.7	5	7.5	10
20	92	20.00	40.9	20.4	5.5	10	10	4	40	23.0	22.6	5	8.0	12
25	98	25.00	48.4	22.9	6.6	11	14	6	45	27.5	27.0	7	5.0	16
35	135	35.00	68.9	32.9	9.0	15	14	6	62	37.5	37.0	7	7.5	20
45	165	45.00	82.4	36.4	11.0	18	14	6	80	46.5	46.0	7	9.5	24

Size	h11	L8	L9	L11	L12	t2	t3	N1	N2	N3	PF1	PF2	S1	S2	S3
12	6	29	57	min.10	40	5.5	1.4	M4	M3	M4	5.5	3.4	3.4	4.9	9.7
15	8	34	68	min.10	60	6	2.0	M5	M4	M6	7.0	4.4	4.9	5.9	12.4
20	11	42	80	min.10	60	7	2.0	M6	M5	M6	9.5	4.9	5.9	5.9	16.9
25	13	48	84	min.10	60	10	2.5	M8	M5	M8	12.0	6.4	7.4	8.9	19.4
35	20	67	117	min.12	80	11.5	3.5	M10	M6	M8	17.0	8.9	8.9	8.9	28.4
45	22	83	146	min.16	105	14.5	4.0	M12	M8	M8	22.0	9.9	9.9	8.9	30.9

Order Instructions

Size	Version	Order No.	
		Pair of Roller Shoes RS-FE	Pair of Single Rails GDL-FE
12	Standard	20930	20928
	Stainless	-	-
15	Standard	20512	20500
	Stainless	20877	20892
20	Standard	20513	20501
	Stainless	20878	20893
25	Standard	20514	20502
	Stainless	20879	20894
35	Standard	20833	20825
	Stainless	20880	20895
45	Standard	20834	20826
	Stainless	20881	20896
12	Low Cost	20995	-
15	Low Cost	20515	-
20	Low Cost	20516	-
25	Low Cost	20517	-
35	Low Cost	20835	-
45	Low Cost	20836	-

Standard Version with Wiper

Standard Version with wiper

Integrated into an additional cover, the felt wiper is impregnated with oil.

Depending on the degree of contamination, these wipers last for some 6000 km, after which the felt wipers can either be washed or replaced.

For optimal functionality, all holes in the guide rails should be filled with the plastic plugs.

Order Instructions Wiper-Spares

for size	for version - Standard - Low Cost - Stainless
12	20996
15	20813
20	20814
25	20815
35	20816
45	20817

Delivery information:

- Scope of supply – 1 pair
- with your order, please indicate whether a bonded, screwed or clipped version is required

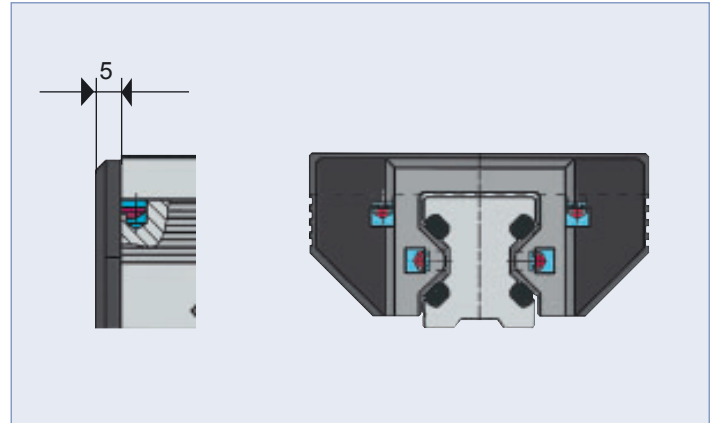
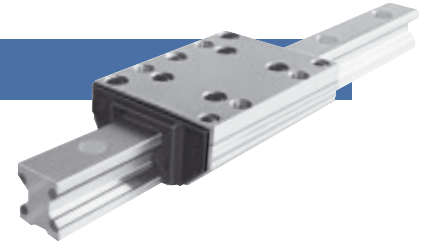

Version with Position Lock

Version with Position Lock

This version features a rotating knob, which locks the carriage into position at any desired point of the track.

The mechanism does not exert any force on the guide system.

The position lock is used in applications where the carriage is moved manually, clamping applications and tooling stations.

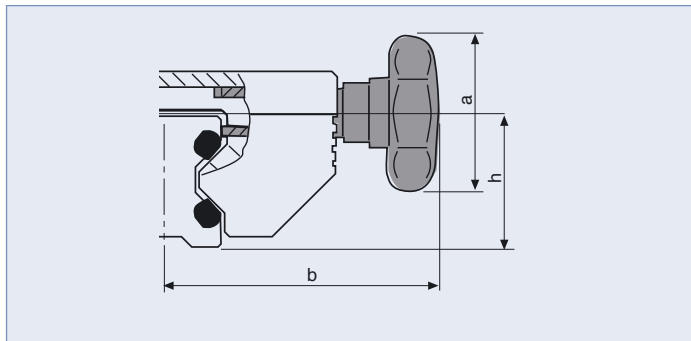

Dimensions (mm), Order Instructions for cassettes with Position Lock

for size	Dimension (mm)			Holding torque (N)	Order No.
	øa	b	h		
12	–	–	–	–	–
15	25	41	19.0	200	20923
20	25	49	23.0	250	20924
25	32	56	28.0	250	20925
35	50	83	38.5	350	20926
45	63	101	48.0	750	20927

by normally holding torque

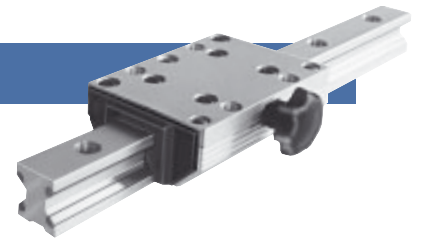

Cap Plugs

Cap Plugs

Material:

wear-free plastic, oil- and ageing resistant

Installation:

- place cap plug in screw recesses.
- position plastic plate on top and drive caps in evenly.
- remove any protruding burr.

Ordering information:

When ordering single or double rails, the required number of caps will be included in the scope of supply.

Dimensions (mm), Order Instructions for Cap Plugs

for size	Dimension (mm) cyl. Scr. DIN 912	øD	Order No.
12	M3	6	20997
15	M4	8	20524
20	M5	10	20525
25	M6	11	20526
35	M8	15	20841
45	M10	18	20842

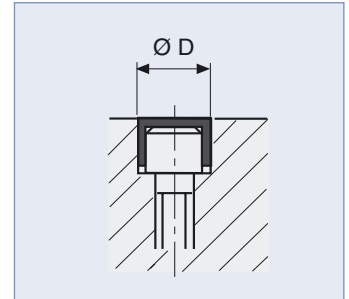

Limit Stop Screw

Limit Stop Screw

The sole purpose of the limit stop screws is to prevent removal of the cassette.

They are screwed in to the thread (option) of the guide rails, a rubber cap placed on top dampens the stop in each case but is unable to absorb the energy produced (resulting damage to the plastic wiper can occur).

For rail lengths where the initial mounting distance of the limit stop screw is less than the L11min, the drill pattern will move up one half of the standard bore length.

Material:

Chlorbutadien Rubber (Cr), black

Dimension (mm), Order Instructions for Limit Stop Screws

for size	Dimension(mm)			L11 min.	P	Order No. Standard	Stainless
	d	D	K				
12	M5	12	8	15	6	20998	20999
15	M5	12	8	16	6	20527	20902
20	M5	12	8	17	6	20527	20902
25	M6	15	10	20.5	7.5	20528	20903
35	M8	19	13	26.5	9.5	20529	20904
45	M10	24	16	33	12	20844	20905

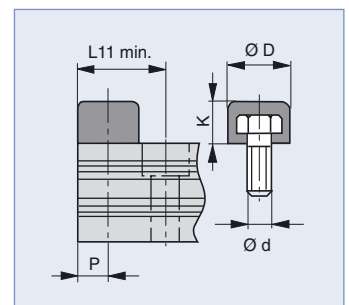

General information

1. Features of the guide system

Aluminium roller guides consist of double rail and roller cassettes resp. individual rail and roller shoe.

Their special features are: light weight, small dimensions, and high speed of displacement. Aluminium roller guides are economical and universal handling components, which are corrosion-resistant and cost effective.

With aluminium roller guides the guide rails and cassettes are made of aluminium. The rollers are running in an antifrictional way on ground or drawn raceways from high alloy spring steel. The special O-arrangement of the running rollers guarantees high load capacity from whatever direction.

2. Size of the guide system

To select the right size, first the moments and forces acting on the bearing have to be determined.

Recommended safety (with screws quality 8.8):

Thrust load: $S > 1.2$
 Tensile load: $S > 2.5$
 Moment load: $S > 4.0$

3. Material

The basic body of HOERBIGER-ORIGA aluminium roller guides is made of aluminium.

The races consist of tough, high alloy spring or of non-corrosive steel.

By using an aluminium construction the moving mass is reduced, enabling

Generally the first decision has to be whether the guide system should be built with double rails and cassettes, or whether individual rails with roller shoes, are to be used. Hereby there are a number of variants.

light weight construction with low moving forces and reduced energy consumption.

Nevertheless the integrated HOERBIGER-ORIGA system sustains high load rating and moment loads.

4. Operating temperature

HOERBIGER-ORIGA bearing elements can be operated within a temperature range from -10° up to $+80^{\circ}\text{C}$.

For other temperatures please consult us.

5. Screwed connections

The units are fixed to the mating structure by the bore holes in the rails and the guides. Hereby the screw quality should be 8.8, washers DIN 433.

To secure the screwed connections we recommend you to use suitable locking means.

6. Wipers

The races of aluminium roller guides and linear guides are equipped with

Tightening moments

Quality 8.8	Weight	Mom. [Nm]
	M3	1.1
	M4	2.5
	M5	5.0
	M6	8.5
	M8	21.0
	M10	41.0
	M12	71.0

wipers against coarse environmental contamination. For rail recess covers see page 9.

7. Slide resistance, adjustment

7.1 Double rail and cassette

Aluminium roller guides are adjusted in such a way that the required stiffness under load is obtained. We recommend that you measure the slide resistance as shown below. However, before doing so the mating structure should be checked for dimensional accuracy and flatness.

The cassettes which are mounted on the rails are adjusted clearance-free ex works. This adjusting mode refers to the point on the rail where the cassette moves most smoothly. Adjustment is effected in the non-loaded condition. The indications on the table are referred to this condition.

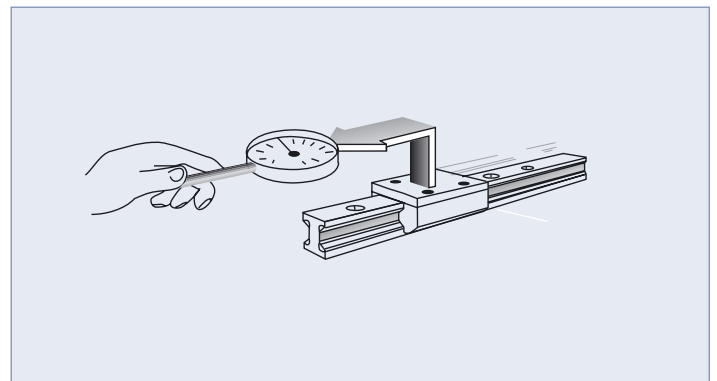

Settings for the standard and rustproof versions

Description	Slide resistance [N]					
	12	15	20	25	35	45
Size	12	15	20	25	35	45
Adjust. value	0.2	1.0	1.5	1.5	3.0	3.5
Max. value	0.5	3.0	4.5	3.0	9.0	10.5

Settings for the LOW COST version

Description	Slide resistance[N]					
	12	15	20	25	35	45
Size	12	15	20	25	35	45
Adjust. value	0.2	0.5	1.0	1.5	2.0	2.5
Max. value	0.4	1.0	2.0	3.0	4.0	5.0

Tolerances in the guide system and internal friction may cause an increase of the slide resistance when the adjusted cassette is moved along the stroke path.

All values without wipers

7.2 Double rail and roller cassette

For clearance setting first the screws of the cassette plate are slightly released, afterwards the threaded pin which is integrated in the longitudinal side of the cassette is set. Turning the threaded pin effects a displacement of the roller

shoe in relation to the cassette plate. After tightening of the cassette plate the slide resistance can be checked. Afterwards the mating structure is fixed.

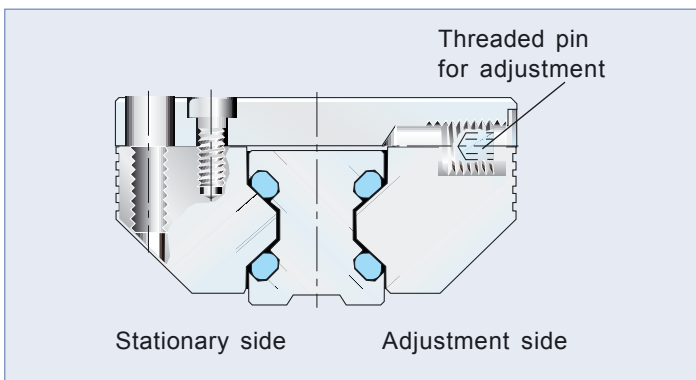

7.3 Single rail and roller shoes

When adjusting the assembly, first indentify the stationary and the adjustable roller shoes.

(see drawing 10.2)

The roller shoes of the stationary side are aligned to the mating structure and fastened by all screws.

With the roller shoes of the stationary side, all fastening screws are slightly tightened. Clearance setting is effected in the same way as with the cassette.

Principally clearance setting is effected in unloaded condition.

7.4 Centering groove on the stationary side

The roller shoes are provided with centering grooves for better alignment during mounting. To use these, centering shoulders according to the data given below, are required.

Size	Mass (mm)	
	a	b
12	4.5	9.6
15	5.0	12.6
20	7.5	16.1
25	10.5	17.6
35	12.5	26.1
45	15.5	31.1

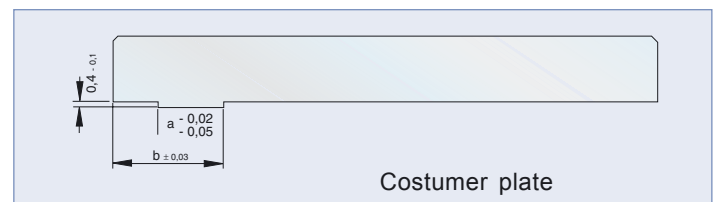

8. Running accuracy

The running accuracy is measured from the screw-on-surface of the cassette to

the ideal straight line of stroke. It is 0.06 mm.

9. Contact and support surfaces

The contact and support surfaces exert a substantial influence on the function and precision of linear guides. Depending on the functional requirements of the system the mating structure must be machined with the corresponding degree of precision.

Machining errors on the mating structure are added to the running errors of the guide system. In order to guarantee troublefree operation we recommend to a max. accumulated deviation of < 0.1 mm per running meter of the guide distance on the mating structure.

General information

10. Design hints

10.1 Double rail and cassette

With the double track arrangement, precise alignment in terms of parallelism and height is necessary.

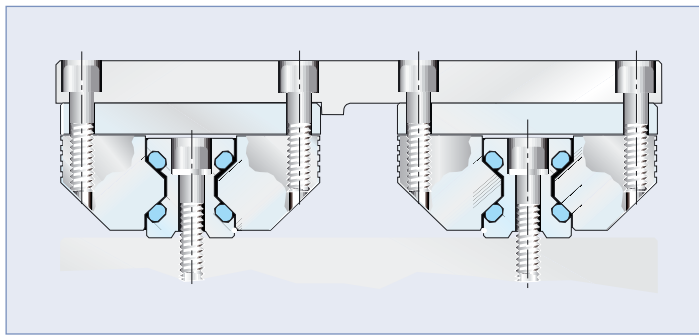

10.2 Single rail and roller shoes

Aluminium roller guides consisting of single rails and roller shoes can be varied in the guide width. They are particularly suitable for assembly on profiled

aluminium carriers, as their corrosion and temperature behaviour is homogenous.

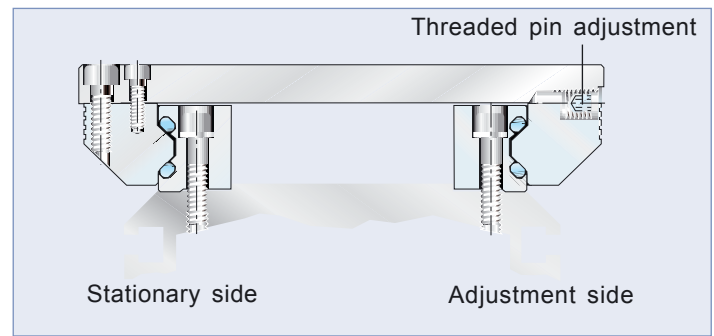

Mounting instructions

11. Mounting instructions

The usable load capacity is influenced by the connection

between the guide elements and the mating structure.

11.1 Double rails and cassettes

Depending on the load situation double rails should either be screwed or screwed and dowelled, and placed in grooves or against a shoulder. The rails rest against shoulders and are screwed or screwed and dowelled to the mating structure.

After final checking of the linearity resp. parallelism the screws are tightened alternately from the center outwards to the given torque.

Afterwards, the cassette should be moved over the total stroke distance, if the motion is uniform then the mounting process may be continued

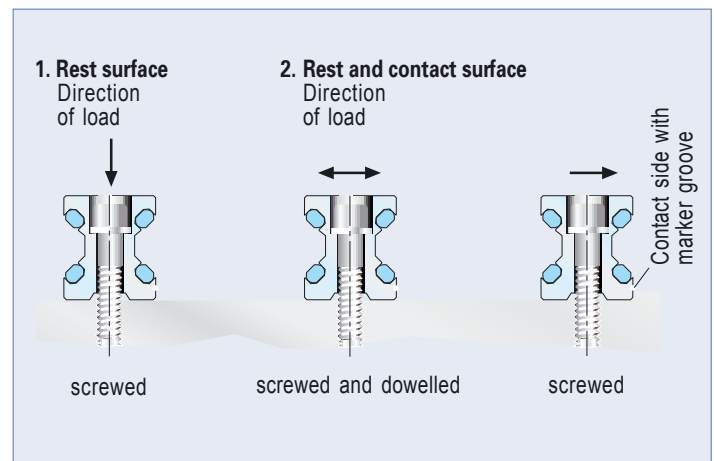

Mounting instructions

11.2 Stationary and movable rest side

With multitrack arrangement first define the a stationary and movable side of the guide. This way tolerances in parallelism can be best compensated.

With multitrack arrangements the movable side of the bearing is equipped with driver and locking device. The floating slider plate has a stationary and a movable side.

The stationary side provides the guiding function, the movable side compensates tolerances in parallelism and height.

We recommend that the drive be placed at the stationary side use this side sustains the driving torque.

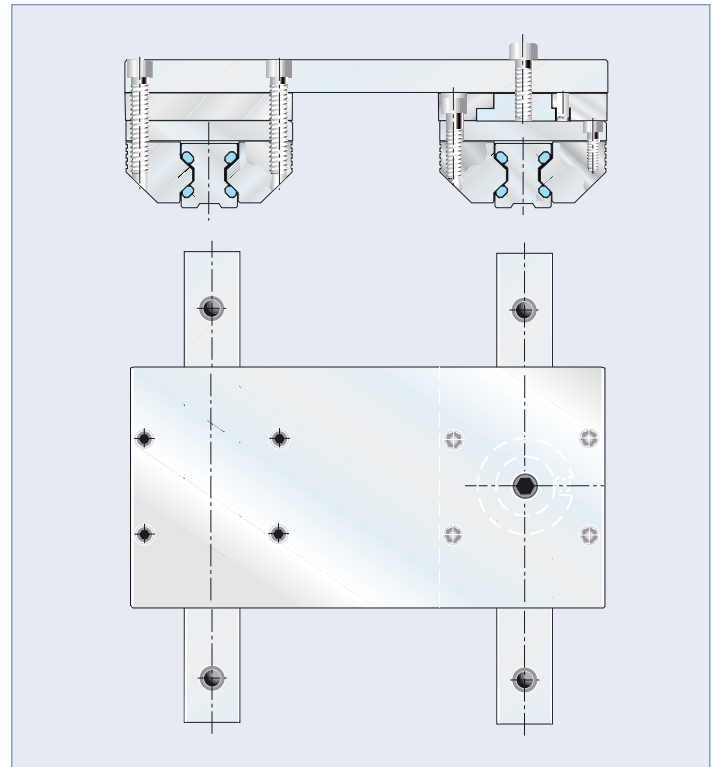

11.3 Single rails and roller shoes

Where single rails and roller shoes are used the mating structure takes the function of the slider.

The guide rails are put against the contact shoulder and screwed resp. screwed and dowelled. After final

adjustment of linearity resp. parallelism the screws are tightened alternately starting from the center outwards.

Afterwards the slider is moved along the guide path. When the movement is uniform you can proceed with mounting.

12. Coupling of guide rails

12.1 Spacing

Coupled rails with a length over $L = 4000$ mm are pieced together according to the HOERBIGER-ORIGA standard. Spacing according to the HOERBIGER-ORIGA standard guarantees a uniform bore shape over the whole guide and an optimum utilisation of the guide length.

For further mounting proceed as described under point 11.

Pitch according to HOERBIGER-ORIGA standard: e.g. GDL-FD35-11400

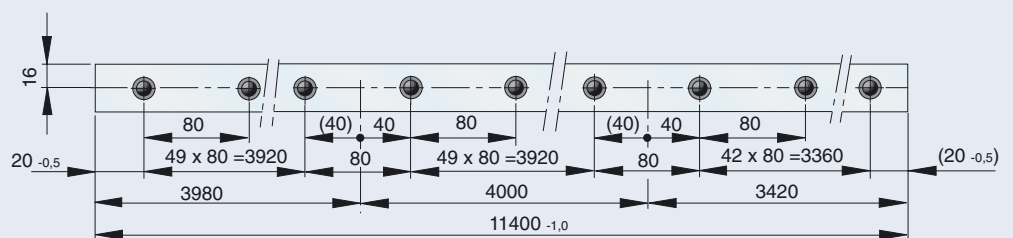

Mounting instructions

12.2 Mounting

Clean contact and mounting surfaces, then place the rails loosely on the guide path one behind the other. With this the correct sequence of the production numbers has to be kept. (e.g. ...1...2...3...4 etc.).

The marking groove on the lower surface of the rail must always be on the same side.

The complete guide path should be aligned without gaps and lightly fastened, ensuring that joints are precisely aligned.

The joints are to be aligned exactly. This is effected best by means of two auxiliary cylinders (length 200 mm). They are inserted into the raceway at the joints and clamped with a device.

For further mounting procede as described under point 11.

Size	Auxiliary cyl. ø (mm)
12	11
15	11
20	14
25	16
35	27
45	35

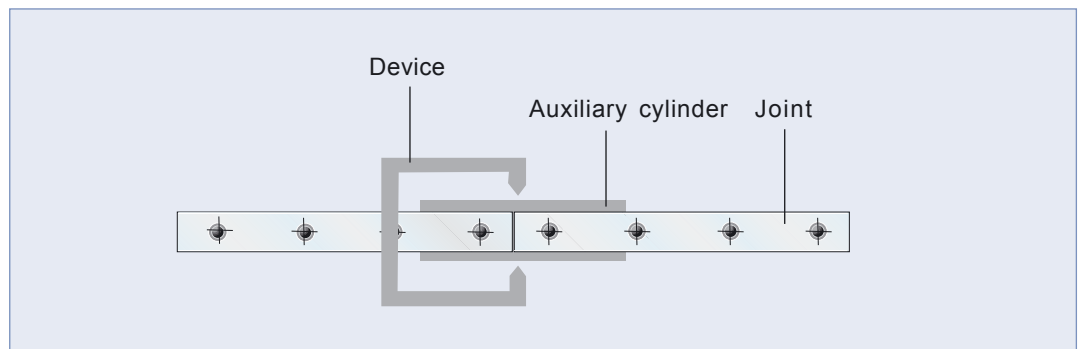

with global service and distribution

for more information visit the following web sites

www.hoerbiger-origa.com

www.interact-system.com

www.airfit.com

www.hoerbiger.com

or contact your local HOERBIGER-ORIGA company

AT	HOERBIGER-ORIGA Pneumatik GmbH • Dr. Alexander-Schärf-Straße 12 • AT-2700 Wiener Neustadt • Tel. +43 (0)2622 26071-0 • Fax +43 (0)2622 26071-5 • e-mail: amarket@hoerbiger-origa.com
AU	HOERBIGER AUSTRALIA PTY.LTD. • 21 David Street • AU-3175 Dandenong, Victoria • Tel. +61 (0)3 9793 9488 • Fax +61 (0)3 9706 8152 • e-mail: origa@hoerbiger.com.au
CH	HOERBIGER-ORIGA AG • Industriestr. 30 • CH-8112 Otelfingen (Zürich) • Tel. +41 (0)1 846 6860 • Fax +41 (0)1 846 6870 • e-mail: chsales@hoerbiger-origa.com
CN	HOERBIGER (WUXI) AUTOMATION TECHNOLOGY CO., LTD. • A2-A, Machinery & Electronics Park • Wuxi National High-Tech Zone • Wuxi 21402, China • Tel. +86 510 520 3468 • Fax +86 510
DE	HOERBIGER-ORIGA GmbH • Industriestr. 8 • DE-70794 Filderstadt • Tel. +49 (0)7158 1703-0 • Fax +49 (0)7158 64870 • e-mail: dmarket@at.hoerbiger.com
ES	HOERBIGER-ORIGA S.A. • Pol. Ind. El Nogal • c/Nogal 8 • ES-28110 Algete (Madrid) • Tel. +34 91 629 09 00 • Fax +34 91 629 24 08 • e-mail: origa@hoerbigeroriga.es
FR	HOERBIGER-ORIGA S.A. • 11 avenue de Norvège • FR-91978 Courtaboeuf • Tel. +33 (0)1 69 29 22 00 • Fax +33 (0)1 69 29 22 10 • e-mail: fmarket@hoerbiger-origa.com
GB	HOERBIGER-ORIGA Ltd. • Tewkesbury Industrial Estate • Tewkesbury GL20 8 ND GB • Tel. +44 1684 85 00 00 • Fax +44 1684 85 05 55 • e-mail: sales@hoerbiger-origa.com
IT	HOERBIGER-ORIGA S.R.L. • Via Martiri della Libertà 4/6 • IT-20060 Liscate (MI) • Tel. +39 02 95 35 03 07 • Fax +39 02 95 35 05 13 • e-mail: itmarket@hoerbiger-origa.com
JP	HOERBIGER AUTOMATION TECHNOLOGY Japan representative office • 501, 2-17-11 Shin-Yokohama • JP-222-0033 Kohokoku, Yokohama • Tel. +81 (0)45 4760 636 • Fax +81 (0)45 4760 637 • e-mail: tadashi.andho@at.hoerbiger.com
NO	HOERBIGER-ORIGA AS • Grønland 57 • NO-3045 Drammen • Tel. +47 3 288 08 40 • Fax +47 32 82 83 20 • e-mail: semarket@hoerbiger-origa.com
NL	HOERBIGER-ORIGA BV • Guldengarde 6 • NL-5234 GG's Hertogenbosch • Tel. +31 73 644 1881 • Fax +31 73 644 1962 • e-mail: nlmarket@hoerbiger-origa.com
MY	HOERBIGER-ORIGA Sdn Bhd • 12 Jalan USJ 7/3A Subang Jaya • MY 47610 Petaling Jaya (Selangor) • Tel. +60 (0)3 734 78 22 • Fax +60 (0)3 734 78 23 • e-mail: sgmarket@hoerbiger-origa.com
PT	HOERBIGER-ORIGA S.A. • Rua Luz Soriano, 42 • P-4200-380 Porto • Tel. +35 1 22 550 71 79 • Fax. +35 1 22 509 22 51 • e-mail: hoerbigerportugal@sapo.pt
SG	HOERBIGER-ORIGA Pte Ltd • 5012 '05-01 Ang Mo Kio Ave 5, Techplace II • SG-569876 Singapore • Tel. +65 6483 2959 • Fax +65 6483 29 79 • e-mail: sgmarket@hoerbiger-origa.com
SE	HOERBIGER-ORIGA AB • Kungsgatan 14, Box 67 • SE-73622 Kungsör • Tel. +46 227 411 00 • Fax +46 227 411 29 • e-mail: semarket@hoerbiger-origa.com
US	HOERBIGER-ORIGA Corporation • 100 West Lake Drive • IL-Glendale Heights, Illinois • Tel. +1 630 871 830-0 • Fax +1 630 871 1515 • e-mail: usmarket@hoerbiger-origa.com
ZA	HOERBIGER-ORIGA (SA) (PTY) Ltd • P.O. Box 17846 • ZA-Randhart 1457 • Tel. +27 (0)11 908 13 10 • Fax +27 (0)11 908 13 12 • e-mail: gunter@hoerbigerco.za

Additional representatives can be found on the Internet

The Strategic Business Units of the HOERBIGER Group

Your Contact

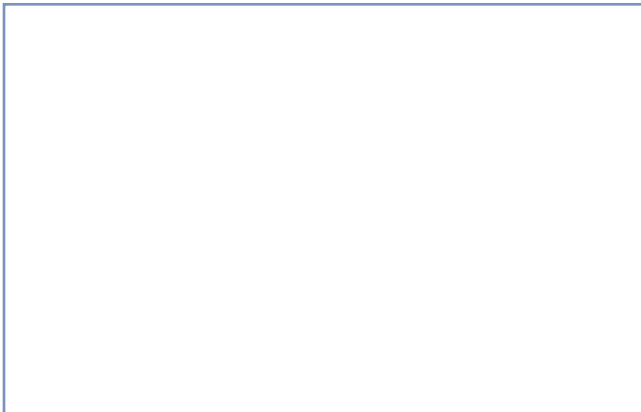

SBU Compression Technology



SBU Automation Technology



SBU Drive Technology

The right to introduce technical modifications is reserved