

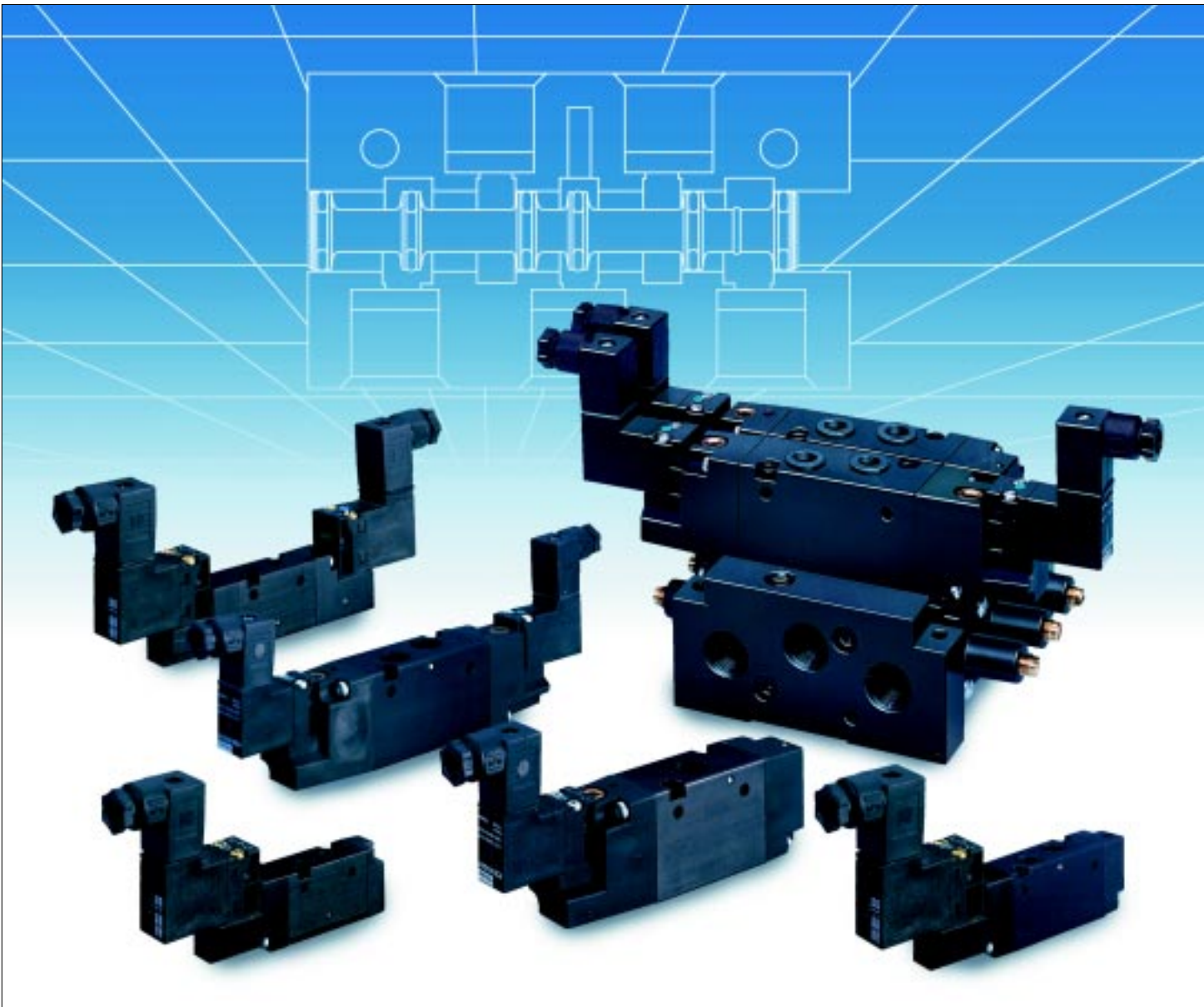

B Series Valves

*High Flow Inline, Manifold Mounted,
Solenoid & Pilot Operated, Threaded
Ports and Push-in Connections*

Catalogue no. 2137GB-ca



- Compact size
- Inlet-exhaust-mounted facility
- Fast response, high flow
- Integrated mounting holes
- Wear compensation System

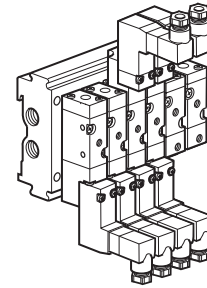

















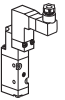

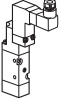

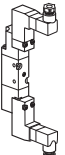



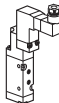

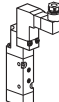

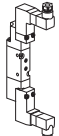

For detailed information see technical leaflet 2127

Operating information

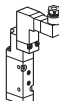
Working pressure	1,5 to 10 bar	Flow (3/2) and (5/2); (acc. to ISO 6358)	C=0,6 b=0,32 Qn=2,8 l/s Qmax=4,2 l/s Cv=0,17
Working temperature; Pneumatically operated	-10°C to +60°C		
Electrically operated	-10°C to +60°C		
Port size	M5		

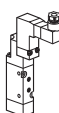
Main data for Directional control valves, B2 Series

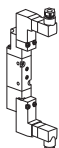
Symbol	Actuator	Return	Signal pressure min, bar at 6 bar actua./return	Changeover time, ms at 6 bar actua./return	Weight Kg	Voltage	Order code	D
Pneumatically actuated 3/2 valves								
 	Air	Differential Air/Spring	3,5/	32/33	0,04		B2XC000XXM8F	1
 	Air	Air	1,5/1,5	17/18	0,05		B2MC000XXM8F	1
Pneumatically actuated 5/2 valves								
 	Air	Differential Air/Spring	3,5/	32/33	0,05		B2FC000XXF	1
 	Air	Air	1,5/1,5	17/18	0,05		B24C000XXF	1
Electrically actuated 3/2 valves								
 	Electric	Differential Air/Spring	3,5/	14/26	0,09 0,04	24 VDC Less solenoid	B2VCBB549M8F B2VCBXXXXM8F	1 1
 	Electric	Air	1,5/1,5	12/13	0,10 0,05	24 VDC Less solenoid	B2SCBB549M8F B2SCBXXXXM8F	1 1
 	Electric	Electric	1,5/1,5	12/12	0,14 0,05	24 VDC Less solenoid	B2JCBB549M8F B2JCBXXXXM8F	1 1

Symbol	Actuator	Return	Signal pressure min, bar at 6 bar actua./return	Changeover time, ms at 6 bar actua./return	Weight Kg	Voltage	Order code	D
Electrically actuated 5/2 valves								
		Electric	Differential	3,5/	14/26	0,09 24 VDC	B2ECBB549F	1
			Air/Spring			0,05 Less solenoid	B2ECBXXXXF	1
		Electric	Air	1,5/1,5	12/13	0,09 24 VDC	B2ACBB549F	1
						0,05 Less solenoid	B2ACBXXXXF	1
		Electric	Electric	1,5/1,5	12/12	0,15 24 VDC	B22CBB549F	1
						0,05 Less solenoid	B22CBXXXXF	1
Pneumatically actuated 3/2 valves (with 5/2 ports centres, to fit on 5/2 manifold)								
		Air	Differential	3,5/-	32/33	0,04	B2XC000XXC	1
			Air/Spring					
		Air	Air	1,5/1,5	17/18	0,05	B2MC000XXC	1
Electrically actuated 3/2 valves (with 5/2 ports centres, to fit on 5/2 manifold)								
		Electric	Differential	3,5/-	14/16	0,09 24 VDC	B2VCBB549C	1
			Air/Spring			0,04 Less solenoid	B2VCBXXXXC	1
		Electric	Air	1,5/1,5	12/13	0,09 24 VDC	B2SCBB549C	1
						0,04 Less solenoid	B2SCBXXXXC	1
		Electric	Electric	1,5/1,5	12/12	0,15 24 VDC	B2JCBB549C	1
						0,05 Less solenoid	B2JCBXXXXC	1

Internal air supply to differential pilots and solenoids via port 1

Inlet-exhaust manifolds

By utilising the alternative vertical integral mounting holes it is possible to mount the valve directly on to a gang manifold, providing common inlet and exhaust facilities.

The aluminium manifolds is available for both 3/2 and 5/2 versions and features a 35 mm DIN rail mounting facility for easy installation of manifolds

Manifold fixing methods

Flat mounted

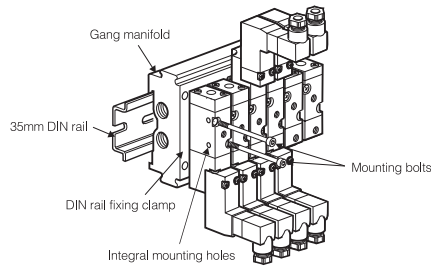
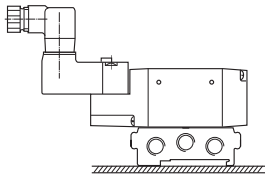

35 mm DIN rail mounted

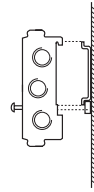

Note!
Manifolds supplied complete with gaskets and mounting screws
Ports 1, 3, 5=G1/8

Main data for manifold kits

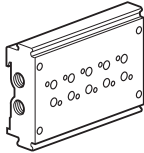
Type	Stations	Weight Kg	Order code	D
3/2 	2	0,152	B805023	1
	3	0,206	B805033	1
	4	0,260	B805043	1
	5	0,314	B805053	1
	6	0,368	B805063	1
	7	0,422	B805073	1
	8	0,476	B805083	1
	9	0,530	B805093	1
	10	0,584	B805103	1
	11	0,638	B805113	1
	12	0,692	B805123	1
	13	0,746	B805133	1
	14	0,800	B805143	1
	15	0,854	B805153	1
	16	0,908	B805163	1
	17	0,962	B805173	1
	18	1,016	B805183	1
	19	1,070	B805193	1
	20	1,124	B805203	1
	Blanking plate kit			
3/2			805003	1
5/2			805004	1
35 mm DIN rail clamp kit			805005	1

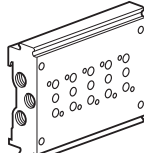
Type	Stations	Weight Kg	Order code	D
5/2 	2	0,184	B805024	1
	3	0,226	B805034	1
	4	0,280	B805044	1
	5	0,344	B805054	1
	6	0,394	B805064	1
	7	0,442	B805074	1
	8	0,492	B805084	1
	9	0,562	B805094	1
	10	0,610	B805104	1
	11	0,668	B805114	1
	12	0,726	B805124	1
	13	0,772	B805134	1
	14	0,836	B805144	1
	15	0,886	B805154	1
	16	0,936	B805164	1
	17	0,990	B805174	1
	18	1,052	B805184	1
	19	1,102	B805194	1
	20	1,160	B805204	1

IEM Aluminium Bar Manifolds

This is the USE Manifold for both 3/2 and 5/2 where the 3/2 is the longer version i.e. part number B2XXXXXXXXF and not the original European MS valve B2XXXXXXXXM8F

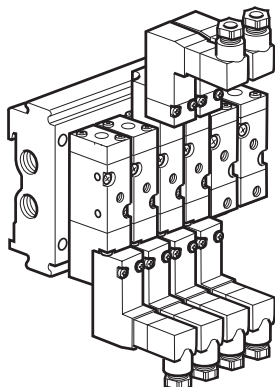

Main data for IEM Aluminium bar manifold

Type	Stations	Weight Kg	Order code	D
	2	0,220	PSM2BXXG02NP	1
	4	0,360	PSM2BXXG04NP	1
	6	0,500	PSM2BXXG06NP	1
	8	0,640	PSM2BXXG08NP	1
	10	0,780	PSM2BXXG10NP	1
	12	0,920	PSM2BXXG12NP	1

Dimensions, B2 valve Series

All dimensions in mm unless otherwise stated

3/2 solenoid operated - air pilot return air spring return

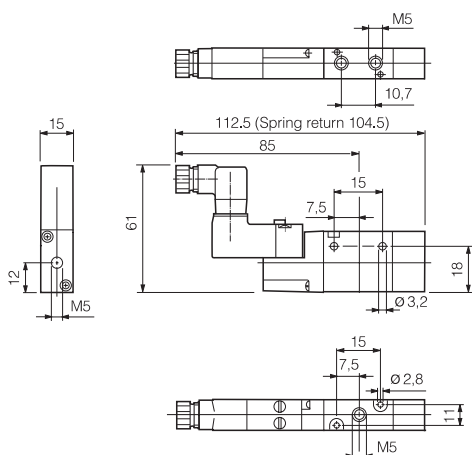

5/2 solenoid operated - air pilot return air spring return

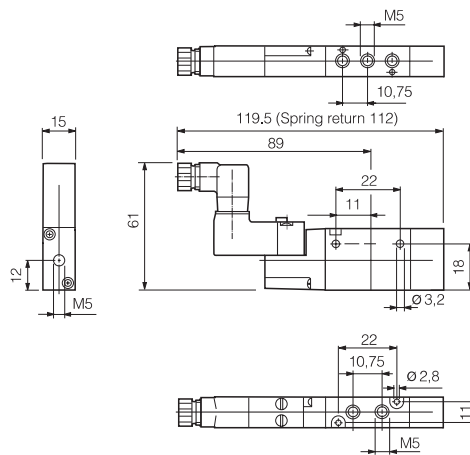

3/2 Double solenoid operated

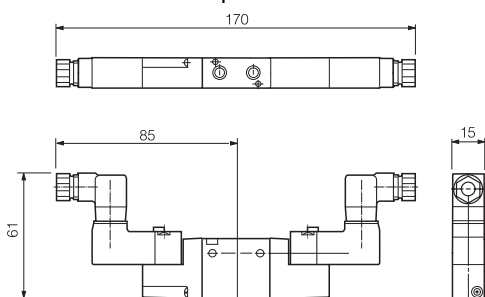

5/2 Double solenoid operated

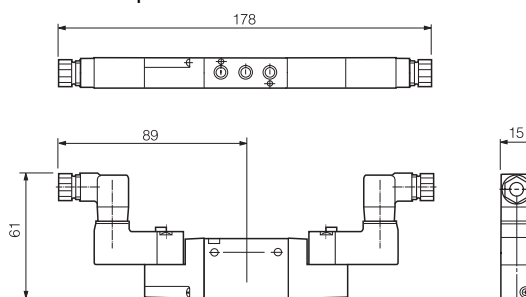

Pilot operated - air spring return

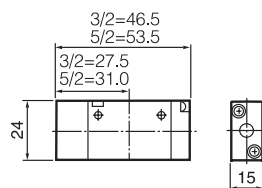

Double pilot operated

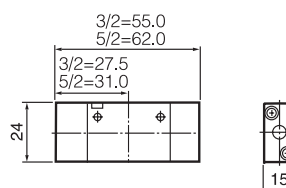

3/2 Manifold

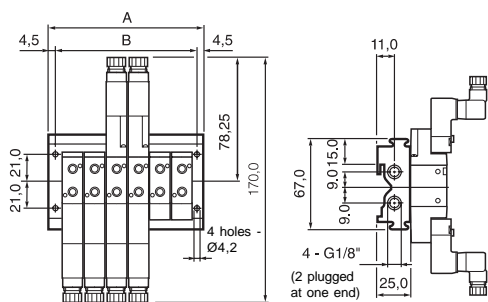

5/2 Manifold

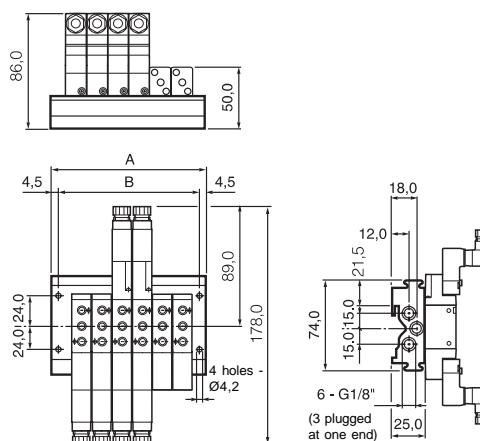

* A for 2 stations=50
* B for 2 stations=41
Add 16 mm per additional station

- Minimum size maximum features
- Inlet-exhaust manifold facility
- DIN rail mounting
- Integral mounting holes
- 1.2 watt solenoid actuators

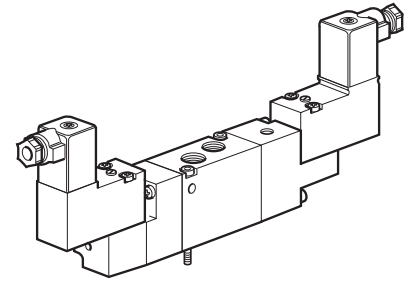













For detailed information see technical leaflet 2133





Operating information

Working pressure	Vacuum - 10 bar	Flow (3/2) and (5/2) (acc. to ISO 6358)	C=2,3 b=0,45 Qn=13 l/s Qmax=16 l/s Cv=0,6
Working temperature; Pneumatically actuated	-10 °C to +50°C		
Electrically actuated	-10 °C to +50°C		

B3		2	5	A	B	5	49	H																																													
<table border="1"> <tr><td colspan="2">Basic series</td></tr> <tr><td>B3</td><td>Ported valve</td></tr> </table>		Basic series		B3	Ported valve	<table border="1"> <tr><td colspan="2">Port size</td></tr> <tr><td>5</td><td>G1/8 all ports</td></tr> <tr><td>K</td><td>6 mm Push-in ports 2 and 4</td></tr> <tr><td>L</td><td>6 mm Push-in all ports</td></tr> </table>		Port size		5	G1/8 all ports	K	6 mm Push-in ports 2 and 4	L	6 mm Push-in all ports	<table border="1"> <tr><td colspan="2">Pilot source / Exh / Vent</td></tr> <tr><td>0</td><td>None (Air pilot only)</td></tr> <tr><td>B</td><td>Port 1 / Vented / Side</td></tr> </table>		Pilot source / Exh / Vent		0	None (Air pilot only)	B	Port 1 / Vented / Side	<table border="1"> <tr><td colspan="2">Engineering Level H</td></tr> <tr><td colspan="2">Voltage</td></tr> <tr><td>XX</td><td>None (Air pilot)</td></tr> <tr><td>49</td><td>24 VDC</td></tr> <tr><td colspan="2">Enclosures</td></tr> <tr><td>0</td><td>None (Air pilot only)</td></tr> <tr><td>X</td><td>None</td></tr> <tr><td>5</td><td>15 mm Connector</td></tr> </table>		Engineering Level H		Voltage		XX	None (Air pilot)	49	24 VDC	Enclosures		0	None (Air pilot only)	X	None	5	15 mm Connector	<table border="1"> <tr><td colspan="2">Overrides / Lights</td></tr> <tr><td>0</td><td>None (Air pilot only)</td></tr> <tr><td>B</td><td>Spring return, flush without light</td></tr> <tr><td>X</td><td>None</td></tr> </table>		Overrides / Lights		0	None (Air pilot only)	B	Spring return, flush without light	X	None		
Basic series																																																					
B3	Ported valve																																																				
Port size																																																					
5	G1/8 all ports																																																				
K	6 mm Push-in ports 2 and 4																																																				
L	6 mm Push-in all ports																																																				
Pilot source / Exh / Vent																																																					
0	None (Air pilot only)																																																				
B	Port 1 / Vented / Side																																																				
Engineering Level H																																																					
Voltage																																																					
XX	None (Air pilot)																																																				
49	24 VDC																																																				
Enclosures																																																					
0	None (Air pilot only)																																																				
X	None																																																				
5	15 mm Connector																																																				
Overrides / Lights																																																					
0	None (Air pilot only)																																																				
B	Spring return, flush without light																																																				
X	None																																																				
<table border="1"> <tr><td colspan="2">Operator / Function</td></tr> <tr><td>1</td><td> 5/2 Single solenoid Differential pilot</td></tr> <tr><td>2</td><td> 5/2 Double solenoid</td></tr> <tr><td>3</td><td> 5/2 Air pilot Differential pilot</td></tr> <tr><td>4</td><td> 5/2 Double air pilot</td></tr> <tr><td>5</td><td> 5/3 Double solenoid Closed centre position</td></tr> <tr><td>8</td><td> 5/3 Double air pilot Closed centre position</td></tr> <tr><td>A</td><td> 5/2 Single solenoid Air pilot return</td></tr> <tr><td>B</td><td> 5/3 Single solenoid Air pilot return Closed centre position</td></tr> <tr><td>G</td><td> 3/2 Single solenoid Differential pilot Normally closed</td></tr> <tr><td>J</td><td> 3/2 Double solenoid Normally closed</td></tr> <tr><td>K</td><td> 3/2 Air pilot operated Differential pilot Normally closed</td></tr> <tr><td>M</td><td> 3/2 Double pilot Normally closed</td></tr> <tr><td>S</td><td> 3/2 Single Solenoid Air pilot return Normally closed</td></tr> </table>		Operator / Function		1	5/2 Single solenoid Differential pilot	2	5/2 Double solenoid	3	5/2 Air pilot Differential pilot	4	5/2 Double air pilot	5	5/3 Double solenoid Closed centre position	8	5/3 Double air pilot Closed centre position	A	5/2 Single solenoid Air pilot return	B	5/3 Single solenoid Air pilot return Closed centre position	G	3/2 Single solenoid Differential pilot Normally closed	J	3/2 Double solenoid Normally closed	K	3/2 Air pilot operated Differential pilot Normally closed	M	3/2 Double pilot Normally closed	S	3/2 Single Solenoid Air pilot return Normally closed	<table border="1"> <tr><td>6</td><td> 5/3 Double solenoid Vented centre position</td></tr> <tr><td>7</td><td> 5/3 Double solenoid Pressurised centre position</td></tr> <tr><td>9</td><td> 5/3 Double air pilot Vented centre position</td></tr> <tr><td>0</td><td> 5/3 Double air pilot Pressurised centre position</td></tr> <tr><td>C</td><td> 5/3 Single Solenoid Air pilot return Vented centre position</td></tr> <tr><td>D</td><td> 5/3 Single Solenoid Air pilot return Pressurised centre position</td></tr> <tr><td>E</td><td> 5/2 Single solenoid Differential pilot with spring assist</td></tr> </table>		6	5/3 Double solenoid Vented centre position	7	5/3 Double solenoid Pressurised centre position	9	5/3 Double air pilot Vented centre position	0	5/3 Double air pilot Pressurised centre position	C	5/3 Single Solenoid Air pilot return Vented centre position	D	5/3 Single Solenoid Air pilot return Pressurised centre position	E	5/2 Single solenoid Differential pilot with spring assist	<table border="1"> <tr><td>F</td><td> 5/2 Single air pilot Differential pilot with spring assist</td></tr> <tr><td>V</td><td> 3/2 Single solenoid Differential pilot with spring assist</td></tr> <tr><td>X</td><td> 3/2 Air pilot Differential pilot with spring assist Normally closed</td></tr> </table>		F	5/2 Single air pilot Differential pilot with spring assist	V	3/2 Single solenoid Differential pilot with spring assist	X	3/2 Air pilot Differential pilot with spring assist Normally closed
Operator / Function																																																					
1	5/2 Single solenoid Differential pilot																																																				
2	5/2 Double solenoid																																																				
3	5/2 Air pilot Differential pilot																																																				
4	5/2 Double air pilot																																																				
5	5/3 Double solenoid Closed centre position																																																				
8	5/3 Double air pilot Closed centre position																																																				
A	5/2 Single solenoid Air pilot return																																																				
B	5/3 Single solenoid Air pilot return Closed centre position																																																				
G	3/2 Single solenoid Differential pilot Normally closed																																																				
J	3/2 Double solenoid Normally closed																																																				
K	3/2 Air pilot operated Differential pilot Normally closed																																																				
M	3/2 Double pilot Normally closed																																																				
S	3/2 Single Solenoid Air pilot return Normally closed																																																				
6	5/3 Double solenoid Vented centre position																																																				
7	5/3 Double solenoid Pressurised centre position																																																				
9	5/3 Double air pilot Vented centre position																																																				
0	5/3 Double air pilot Pressurised centre position																																																				
C	5/3 Single Solenoid Air pilot return Vented centre position																																																				
D	5/3 Single Solenoid Air pilot return Pressurised centre position																																																				
E	5/2 Single solenoid Differential pilot with spring assist																																																				
F	5/2 Single air pilot Differential pilot with spring assist																																																				
V	3/2 Single solenoid Differential pilot with spring assist																																																				
X	3/2 Air pilot Differential pilot with spring assist Normally closed																																																				

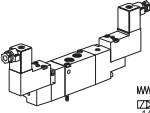
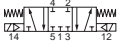
Main data for Directional control valves, B3 Series

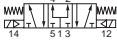
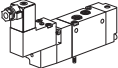
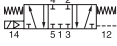
Symbol	Actuator	Return	Signal pressure min, bar at 6 bar actua./return	Changeover time, ms at 6 bar actua./return	Weight Kg	Voltage	Order code	D
Pneumatically actuated 3/2 valves								
	Air	Differential air	1,4/-	16/17	0,07		B3K5000XXH	1
	Air	Differential air with spring assist			0,07		B3X5000XXH	1
	Air	Air	1,4/1,4	2/2	0,08		B3M5000XXH	1
Pneumatically actuated 5/2 and 5/3 valves								
	Air	Differential air	1,4/-	16/17	0,09		B335000XXH	1
	Air	Differential air with spring assist			0,09		B3F5000XXH	1
	Air	Air	1,4/1,4	2/2	0,10		B345000XXH	1
	Air	Air	3,0/3,0	12/12	0,10		B385000XXH	1
	Closed centre self centring position							
	Air	Air	3,0/3,0	12/12	0,10		B395000XXH	1
	Vented centre self centring position							
	Air	Air	3,0/3,0	12/12	0,10		B305000XXH	1
	Pressurised self centring centre position							
Electrically actuated 3/2 valves								
	Electric	Differential air	1,4/-	12/14	0,12	24 VDC	B3G5BB549H	1
		Differential air with spring assist			0,08	Less solenoid	B3G5BXXXXXH	1
	Electric	Differential air with spring assist			0,12	24 VDC	B3V5BB549H	1
					0,08	Less solenoid	B3V5BXXXXXH	1
	Electric	Air	1,4/1,4	9/3	0,13	24 VDC	B3S5BB549H	1
					0,09	Less solenoid	B3S5BXXXXXH	1
	Electric	Electric	1,4/1,4	8/8	0,13	24 VDC	B3J5BB549H	1
					0,09	Less solenoid	B3J5BXXXXXH	1
Electrically actuated 5/2 valves								
	Electric	Differential	1,4/-	12/14	0,12	24 VDC	B315BB549H	1
	Air	Air			0,09	Less solenoid	B315BXXXXXH	1
	Electric	Differential air with spring assist			0,12	24 VDC	B3E5BB549H	1
	Air				0,09	Less solenoid	B3E5BXXXXXH	1
	Electric	Air	1,4/1,4	9/3	0,14	24 VDC	B3A5BB549H	1
					0,10	Less solenoid	B3A5BXXXXXH	1
	Electric	Electric	1,4/1,4	8/8	0,19	24 VDC	B325BB549H	1
					0,10	Less solenoid	B325BXXXXXH	1

Symbol	Actuator	Return	Signal pressure min, bar at 6 bar actua./return	Changeover time, ms at 6 bar actua./return	Weight Kg	Voltage	Order code	D
Electrically actuated 5/3 valves								
	Electric	Electric	3,0/3,0	12/12	0,18	24 VDC	B355BB549H	1
	Closed centre	self centring			0,09	Less solenoid	B355BXXXXH	1
	Electric	Electric	3,0/3,0	12/12	0,18	24 VDC	B365BB549H	1
	Vented centre	self centring			0,09	Less solenoid	B365BXXXXH	1
	Electric	Electric	3,0/3,0	12/12	0,18	24 VDC	B375BB549H	1
	Pressurised	self centring			0,09	Less solenoid	B375BXXXXH	1
	Electric	Electric	3,0/3,0	12/12	0,18	24 VDC	B3B5BB549H	1
	Closed centre	self centring			0,09	Less solenoid	B3B5BXXXXH	1
	Electric	Electric	3,0/3,0	12/12	0,18	24 VDC	B3C5BB549H	1
	Vented centre	self centring			0,09	Less solenoid	B3C5BXXXXH	1
	Electric	Electric	3,0/3,0	12/12	0,18	24 VDC	B3D5BB549H	1
	Pressurised	self centring			0,09	Less solenoid	B3D5BXXXXH	1
								

Internal air supply to differential pilots and solenoids via port 1

Inlet Exhaust Manifolds for B3 series valves

Standard Base without Flow Controls

Each kit contains:

- 1 pcs Manifold Base
- 2 pcs Mounting screws and nuts
- 3 pcs Tie Rods
- 1 pcs Body-to-base Gasket and
- 1 pcs Base-to-Base Gasket

	Order code	D
Manifold Base Kit 3/2 = PS2948F		1
5/2 = PS2917F		1

Base with Flow Controls

Each kit contains:

- 1 pcs Manifold Base with Flow Controls
- 2 pcs Mounting screws and nuts
- 3 pcs Tie Rods
- 1 pcs Body-to-base Gasket
- 1 pcs Base-to-Base Gasket

	Order code	D
Manifold Base Kit 3/2 = PS2949F		1
5/2 = PS2918F		1

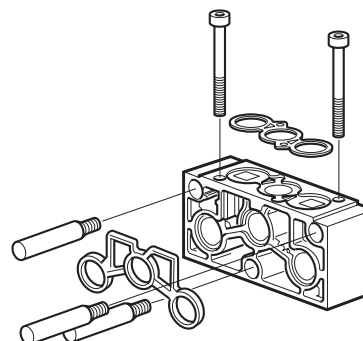

End plates

Standard End Plates may be used with either of above Manifold Bases

Each kit contains:

- 1 right and 1 left End Plate
- 3 pcs O-Rings
- 3 pcs Blanking Plugs
- 3 pcs Socket Head Cap Screws
- 3 pcs Flat Washers
- 3 pcs Lockwashers

	Order code	D
Manifold End 3/2 = PS2951F		1
plate kit 5/2 = PS2916F		1

IEM manifolds are also available with common external supply. A special end plate kit is available with this facility, but valves must be ordered specifically for this purpose. For details consult Technical Sales Department.

	Order code	D
DIN rail mounting kit for IEM manifold	PS2970F	1

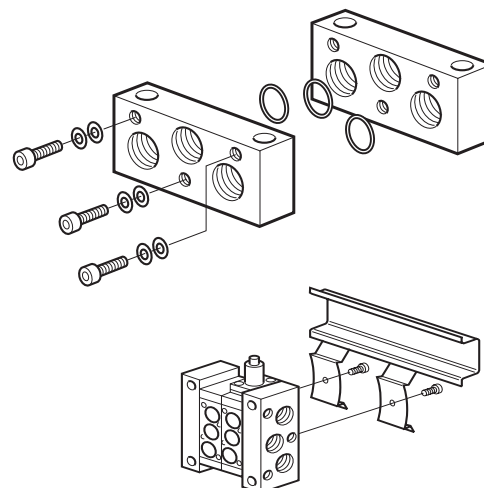

Isolator Plug Kit

Used to isolate the 1, 3 or 5 gallery between two Manifold Bases

Each kit contains:

- 3 pcs Isolator Plugs complete with O-rings

	Order code	D
Isolator Plug kit	PS2919F	1

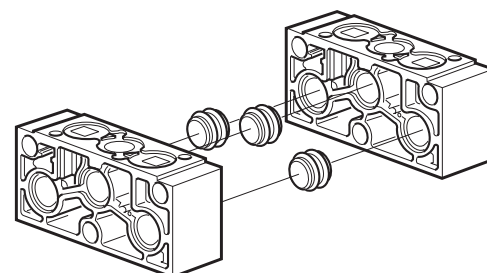

Manifold Ported Plate

Each kit contains:

- 1 pcs Inlet Plate
- 2 pcs Mounting screws
- 3 pcs G1/8 Plugs
- 1 pcs Gasket

	Order code	D
Manifold	3/2 = PS2967F	1
Ported plate	5/2 = PS2921F	1

Manifold Blanking plate

Each kit contains:

- 1 pcs Cover Plate
- 2 pcs Mounting Screws
- 1 pcs Gasket

	Order code	D
Manifold	3/2 = PS2968F	1
Blanking plate	5/2 = PS2969F	1

Used to blank off unused stations.

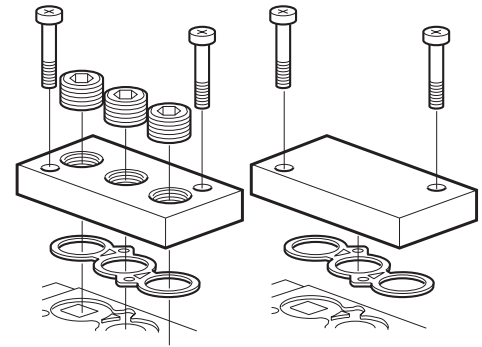

Service kits

Type	Order code	D
3/2 IEM Gasket kit (10 valve/manifold gaskets)	PS2980F	1
5/2 IEM Gasket kit (10 valve/manifold gaskets)	PS2981F	1

Dimensions, B3 valve Series

All dimensions in mm unless otherwise stated

3/2 Body ported

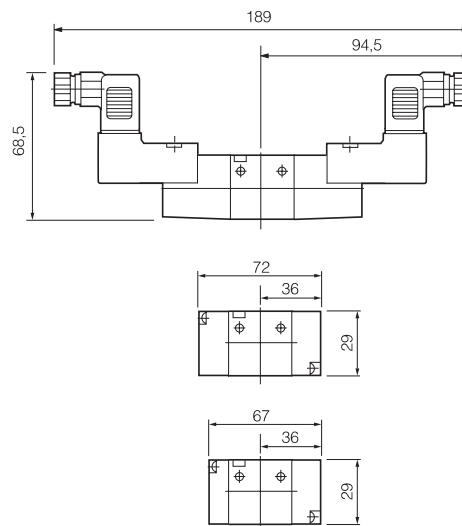
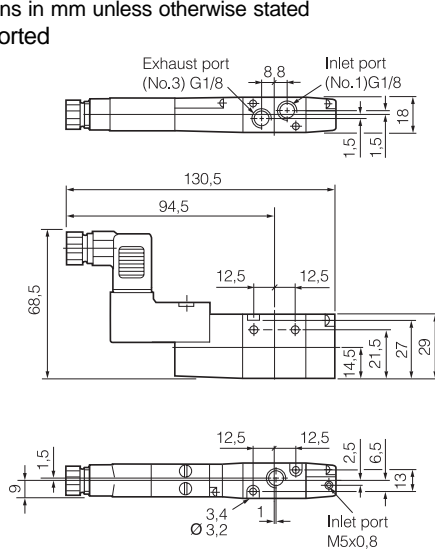

5/2 Body ported

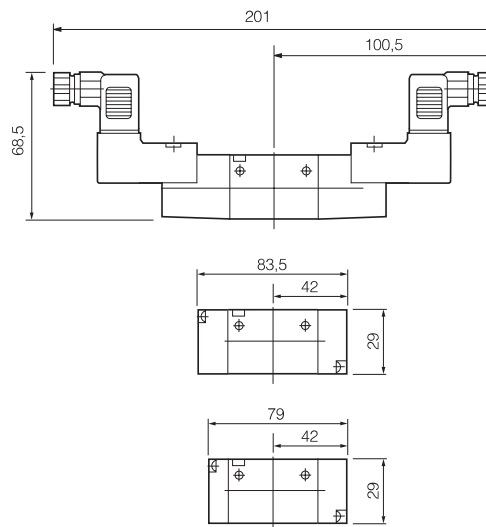
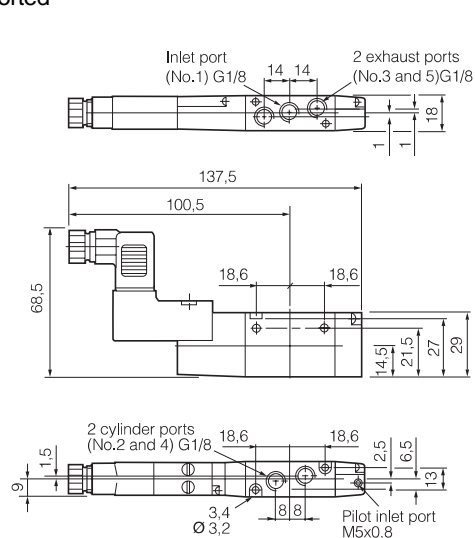

- G1/4 or 8 mm push-in connection
- Inlet-exhaust manifold facility
- DIN rail mounting
- Integral mounting holes
- 1.2 watt solenoid actuators

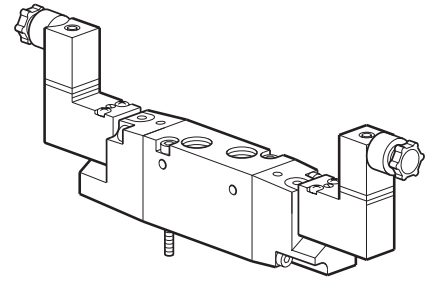

For detailed information see technical leaflet 2135



















Operating information

Working pressure	Max 10 bar
Working temperature; Pneumatically actuated	-10 °C to +60°C
Electrically actuated	-10 °C to +60°C
Flow (3/2) and (5/2) (acc. to ISO 6358)	C=4,56 b=0,30 Qn=19,5 l/s Cv=1,2

Order key

B4 1 6 A 0 0 39 F

	Basic series				Engineering Level F
	B4 Ported valve				

Operator / Function		Port size	
1	 5/2 Single solenoid Differential pilot	6	G1/4 All ports
2	 5/2 Double solenoid	M	8 mm Push-in Connection in ports 1,2 and 4 (5/2 and 5/3)
3	 5/2 Air pilot Differential pilot	L	8 mm Push-in connection in ports 2 and 4 (5/2 and 5/3) 2 (3/2)
4	 5/2 Double air pilot		
5	 5/3 Double solenoid Closed centre position		
6	 5/3 Double solenoid Vented centre position		
7	 5/3 Double solenoid Pressurised centre position		
8	 5/3 Double air pilot Closed centre position		
9	 5/3 Double air pilot Vented centre position		
0	 5/3 Double air pilot Pressurised centre position		
A	 5/2 Single solenoid Air pilot return		
B	 5/3 Single solenoid Air pilot return Closed centre position		
C	 5/3 Single solenoid Air pilot return Vented centre position		
D	 5/3 Solenoid operated Air pilot return Pressurised centre position		
G	 3/2 Single solenoid Differential pilot Normally closed		
J	 3/2 Double solenoid Normally closed		
K	 3/2 Air pilot operated Differential pilot Normally closed		
M	 3/2 Double pilot Normally closed		
S	 3/2 Single Solenoid Air pilot return Normally closed		











Pilot source / Exh / Vent	
0	None (Air pilot only)
A	Port 1 / Tapped / Side
K	External / Tapped / Side
W	Manifold / Tapped / Side

Voltage	
XX	None
49	24 VDC



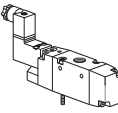

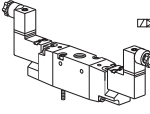
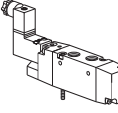





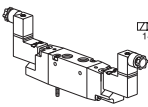

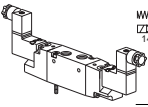

Enclosures	
0	None (Air pilot only)
5	15 mm Connector
X	None

Overrides / Lights	
0	None (Air pilot only)
B	Spring return, flush Without light
X	Solenoid valve Without solenoid

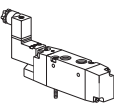













Main data for Directional control valves, B4 Series (G1/4 threaded ports)

Symbol	Actuator	Return	Signal pressure min, bar at 6 bar actua./return	Changeover time, ms at 6 bar actua./return	Weight Kg	Voltage	Order code	D
Pneumatically actuated 3/2 valves								
	Air	Differential Air	1,5/-	34/45	0,163		B4K6000XXF	1
	Air	Air	1,5/1,5	15/17	0,177		B4M6000XXF	1
Pneumatically actuated 5/2 and 5/3 valves								
	Air	Differential Air	1,5/-	34/45	0,184		B436000XXF	1
	Air	Air	1,5/1,5	15/17	0,198		B446000XXF	1
	Air Closed centre position	Air self centring	3,0/3,0	16/19	0,204		B486000XXF	1
	Air Vented centre position	Air self centring	3,0/3,0	16/19	0,204		B496000XXF	1
	Air Pressurised centre position	Air self centring	3,0/3,0	16/19	0,204		B406000XXF	1
Electrically actuated 3/2 valves								
	Electric	Differential Air	1,5/-	34/45	0,206 0,157	24 VDC Less solenoid	B4G6AB549F B4G6AXXXXF	1 1
	Electric	Air	1,5/1,5	15/17	0,220 0,170	24 VDC Less solenoid	B4S6AB549F B4S6AXXXXF	1 1
	Electric	Electric	1,5/1,5	15/15	0,262 0,164	24 VDC Less solenoid	B4J6AB549F B4J6AXXXXF	1 1
Electrically actuated 5/2 valves								
	Electric Air	Differential Air	1,5/-	34/45	0,227 0,178	24 VDC Less solenoid	B416AB549F B416AXXXXF	1 1
	Electric	Air	1,5/1,5	15/17	0,241 0,192	24 VDC Less solenoid	B4A6AB549F B4A6AXXXXF	1 1













Internal air supply to differential pilots and solenoids via port 1

Symbol	Actuator	Return	Signal pressure min, bar at 6 bar actua./return	Changeover time, ms at 6 bar actua./return	Weight Kg	Voltage	Order code	D	
Electrically actuated 5/2 and 5/3 valves									
		Electric	Electric	1,5/1,5	15/15	0,283	24 VDC	B426AB549F	1
						0,185	Less solenoid	B426AXXXXF	1
		Electric	Electric	3,0/3,0	16/18	0,289	24 VDC	B456AB549F	1
			Closed centre self centring position			0,191	Less solenoid	B456AXXXXF	1
			Vented centre self centring position						
		Electric	Electric	3,0/3,0	16/18	0,289	24 VDC	B466AB549F	1
			Vented centre self centring position			0,191	Less solenoid	B466AXXXXF	1
			Pressurised self centring centre position						
		Electric	Electric	3,0/3,0	16/18	0,289	24 VDC	B476AB549F	1
			Pressurised self centring centre position			0,191	Less solenoid	B476AXXXXF	1
		Electric	Air	3,0/3,0	16/19	0,247	24 VDC	B4B6AB549F	1
			Closed centre self centring position			0,198	Less solenoid	B4B6AXXXXF	1
			Vented centre self centring position						
		Electric	Air	3,0/3,0	16/19	0,247	24 VDC	B4C6AB549F	1
			Vented centre self centring position			0,191	Less solenoid	B4C6AXXXXF	1
			Pressurised self centring centre position						
		Electric	Air	3,0/3,0	16/19	0,247	12 VAC	B4D6AB549F	1
			Pressurised self centring centre position			0,191	Less solenoid	B4D6AXXXXF	1

Main data for Directional control valves, B4 Series (8 mm push-in connectors port 2 only 3/2, 5/2 and 5/3)



















Symbol	Actuator	Return	Signal pressure min, bar at 6 bar actua./return	Changeover time, ms at 6 bar actua./return	Weight Kg	Voltage	Order code	D	
Pneumatically actuated 3/2 valves									
		Air	Differential Air	1,5/-	34/45	0,164		B4KL000XXF	1
		Air	Air	1,5/1,5	15/17	0,178		B4ML000XXF	1
Pneumatically actuated 5/2 and 5/3 valves									
		Air	Differential Air	1,5/-	34/45	0,186		B43L000XXF	1
		Air	Air	1,5/1,5	15/17	0,199		B44L000XXF	1
		Air	Air	3,0/3,0	16/19	0,206		B48L000XXF	1
			Closed centre self centring position						
		Air	Air	3,0/3,0	16/19	0,206		B49L000XXF	1
			Vented centre self centring position						
		Air	Air	3,0/3,0	16/19	0,206		B40L000XXF	1
			Pressurised self centring centre position						

Internal air supply to differential pilots and solenoids via port 1

Symbol	Actuator	Return	Signal pressure min, bar at 6 bar actua./return	Changeover time, ms at 6 bar actua./return	Weight Kg	Voltage	Order code	D	
Electrically actuated 3/2 valves									
	Electric	Differential	1,5/-	34/45	0,207	24 VDC	B4GLAB549F	1	
		Air				0,158	Less solenoid	B4GLAXXXXF	1
	Electric	Air	1,5/1,5	15/17	0,220	24 VDC	B4SLAB549F	1	
						0,171	Less solenoid	B4SLAXXXXF	1
	Electric	Electric	1,5/1,5	15/15	0,263	24 VDC	B4JLAB549F	1	
						0,165	Less solenoid	B4JLAXXXXF	1
Electrically actuated 5/2 and 5/3 valves									
	Electric	Differential	1,5/-	34/45	0,229	24 VDC	B41LAB549F	1	
						0,180	Less solenoid	B41LAXXXXF	1
	Electric	Air	1,5/1,5	15/17	0,242	24 VDC	B4ALAB549F	1	
						0,193	Less solenoid	B4ALAXXXXF	1
	Electric	Electric	1,5/1,5	15/15	0,284	24 VDC	B42LAB549F	1	
						0,186	Less solenoid	B42LAXXXXF	1
	Electric	Closed centre	3,0/3,0	16/18	0,291	12 VAC	B45LAB539F	1	
		self centring				0,193	Less solenoid	B45LAXXXXF	1
	Electric	Vented centre	3,0/3,0	16/18	0,291	24 VDC	B46LAB549F	1	
		self centring				0,193	Less solenoid	B46LAXXXXF	1
	Electric	Pressurised	3,0/3,0	16/18	0,291	12 VAC	B47LAB549F	1	
		self centring				0,193	Less solenoid	B47LAXXXXF	1
	Electric	Closed centre	3,0/3,0	16/19	0,291	12 VAC	B4BLAB549F	1	
		self centring				0,193	Less solenoid	B4BLAXXXXF	1
	Electric	Vented centre	3,0/3,0	16/19	0,291	12 VAC	B4CLAB549F	1	
		self centring				0,193	Less solenoid	B4CLAXXXXF	1
	Electric	Pressurised	3,0/3,0	16/19	0,291	12 VAC	B4DLAB549F	1	
		self centring				0,193	Less solenoid	B4DLAXXXXF	1
		centre position							

Internal air supply to differential pilots and solenoids via port 1

Main data for Directional control valves, B4 Series (8 mm push-in connectors, all ports)

Symbol	Actuator	Return	Signal pressure min, bar at 6 bar actua./return	Changeover time, ms at 6 bar actua./return	Weight Kg	Voltage	Order code	D
Pneumatically actuated 3/2 valves								
	Air	Differential Air	1,5/-	34/45	0,154		B4KM000XXF	1
	Air	Air	1,5/1,5	15/17	0,165		B4MM000XXF	1
Pneumatically actuated 5/2 and 5/3 valves								
	Air	Differential Air	1,5/-	34/45	0,186		B43M000XXF	1
	Air	Air	1,5/1,5	15/17	0,175		B44M000XXF	1
	Air Closed centre position	Air self centring	3,0/3,0	16/19	0,192		B48M000XXF	1
	Air Vented centre position	Air self centring	3,0/3,0	16/19	0,192		B49M000XXF	1
	Air Pressurised centre position	Air self centring	3,0/3,0	16/19	0,192		B40M000XXF	1
Electrically actuated 3/2 valves								
	Electric	Differential Air	1,5/-	34/45	0,200 0,151	24 VDC Less solenoid	B4GMAB549F B4GMAXXXF	1 1
	Electric	Air	1,5/1,5	15/17	0,210 0,161	24 VDC Less solenoid	B4SMAB549F B4SMAXXXF	1 1
	Electric	Electric	1,5/1,5	15/15	0,256 0,158	24 VDC Less solenoid	B4JMAB549F B4JMAXXXF	1 1
Electrically actuated 5/2 and 5/3 valves								
	Electric Air	Differential Air	1,5/-	34/45	0,221 0,172	24 VDC Less solenoid	B41MAB549F B41MAXXXF	1 1
	Electric	Air	1,5/1,5	15/17	0,232 0,183	24 VDC Less solenoid	B4AMAB549F B4AMAXXXF	1 1
	Electric	Electric	1,5/1,5	15/15	0,277 0,179	24 VDC Less solenoid	B42MAB539F B42MAXXXF	1 1
	Electric Closed centre position	Electric self centring	3,0/3,0	16/18	0,283 0,187	24 VDC Less solenoid	B45MAB539F B45MAXXXF	1 1
	Electric Vented centre position	Electric self centring	3,0/3,0	16/18	0,283 0,187	24 VDC Less solenoid	B46MAB539F B46MAXXXF	1 1
	Electric Pressurised centre position	Electric self centring	3,0/3,0	16/18	0,283 0,187	24 VDC Less solenoid	B47MAB539F B47MAXXXF	1 1
	Electric Closed centre position	Air self centring	3,0/3,0	16/19	0,238 0,193	24 VDC Less solenoid	B4BMAB539F B4BMAXXXF	1 1
	Electric Vented centre position	Air self centring	3,0/3,0	16/19	0,238 0,193	24 VDC Less solenoid	B4CMAB539F B4CMAXXXF	1 1
	Electric Pressurised centre position	Air self centring	3,0/3,0	16/19	0,238 0,193	24 VDC Less solenoid	B4DMAB539F B4DMAXXXF	1 1

Internal air supply to differential pilots and solenoids via port.

Inlet Exhaust Manifolds for B4 series valves

Standard Base without Flow Controls

Each kit contains:

- 1 pcs Manifold Base
- 2 pcs Mounting screws and nuts
- 2 pcs Tie Rods
- 1 pcs Body-to-base Gasket and
- 1 pcs Base-to-Base Gasket

	Order code	D
Manifold Base Kit	3/2 = PS4548F	1
	5/2 = PS4517F	1

Base with Flow Controls

Each kit contains:

- 1 pcs Manifold Base with Flow Controls
- 2 pcs Mounting screws and nuts
- 2 pcs Tie Rods
- 1 pcs Body-to-base Gasket
- 1 pcs Base-to-Base Gasket

	Order code	D
Manifold Base Kit	3/2 = PS4549F	1
	5/2 = PS4518F	1

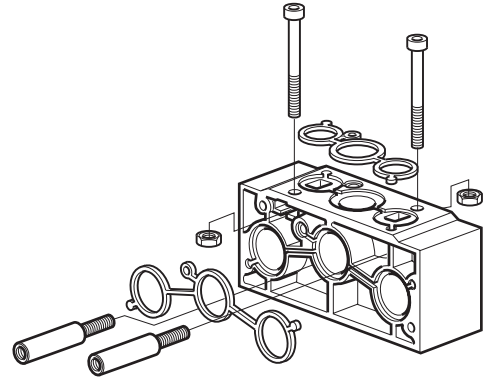

End plates

Standard End Plates may be used with either of above Manifold Bases

Each kit contains:

- 1 right and 1 left End Plate
- 3 pcs O-Rings
- 3 pcs Blanking Plugs
- 2 pcs Socket Head Cap Screws
- 2 pcs Flat Washers
- 2 pcs Lockwashers

	Order code	D
Manifold End plate kit	3/2 = PS4551F	1
	5/2 = PS4516F	1

IEM manifolds are also available with common external supply. A special end plate kit is available with this facility, but valves must be ordered specifically for this purpose. For details consult Technical Sales Department.

	Order code	D
DIN rail mounting kit for IEM manifold	PS4570F	1

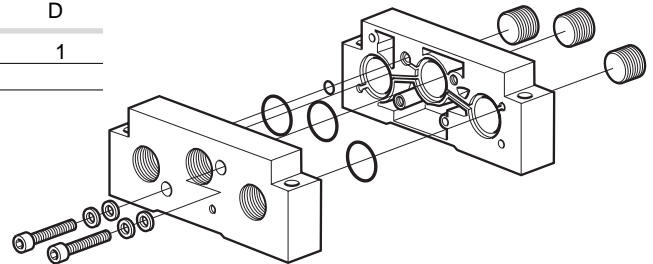

Isolator Plug Kit

Used to isolate the 1, 3 or 5 gallery between two Manifold Bases

Each kit contains:

- 3 pcs Isolator Plugs complete with O-rings

	Order code	D
Isolator Plug kit	PS4519F	1

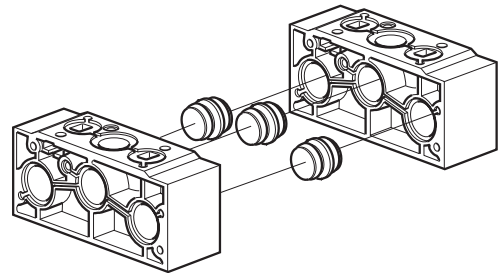

Manifold Ported Plate

Each kit contains:

- 1 pcs Inlet Plate
- 2 pcs Mounting screws
- 3 pcs G1/8 Plugs
- 1 pcs Gasket

	Order code	D
Manifold Ported plate	3/2 = PS4567F	1
	5/2 = PS4521F	1

Manifold Blanking plate

Each kit contains:

- 1 pcs Cover Plate
- 2 pcs Mounting Screws
- 1 pcs Gasket

Used to blank off unused stations.

	Order code	D
Manifold Blanking plate	3/2 = PS4568F	1
	5/2 = PS4569F	1

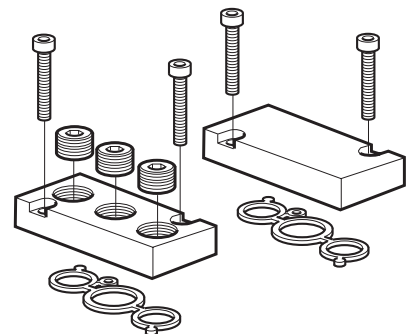

Service kits

Type	Order code	D
3/2 IEM Gasket kit (10 valve/manifold gaskets)	PS4580F	1
5/2 IEM Gasket kit (10 valve/manifold gaskets)	PS4581F	1

Dimensions, B4 valve Series

3/2 Body ported
Single solenoid operated air spring return

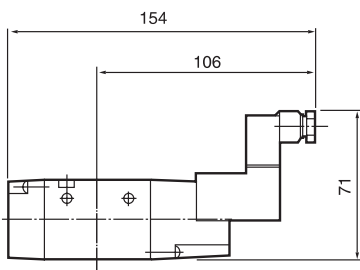

5/2 Body ported
Single solenoid operate air spring return

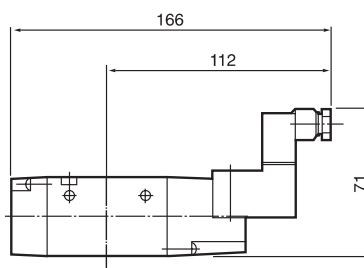

Single solenoid operated air pilot return

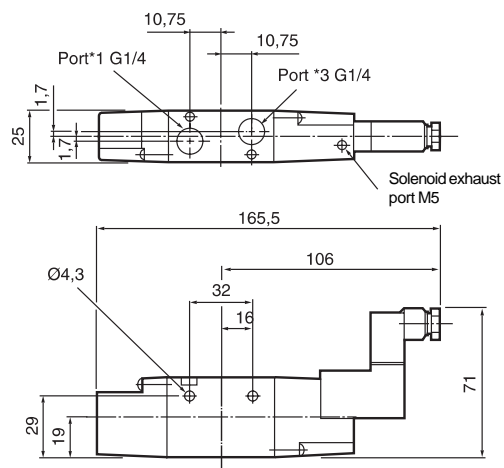

Single solenoid operated air pilot return

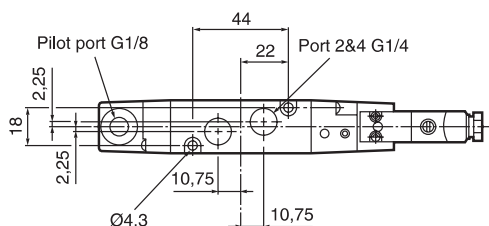
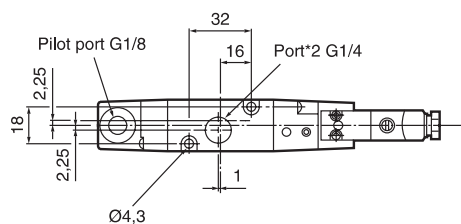
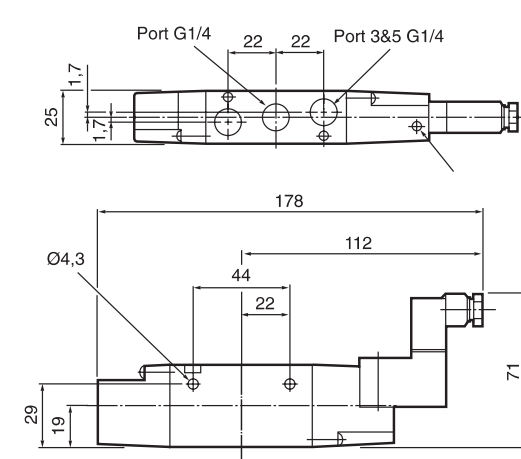

Double solenoid operated

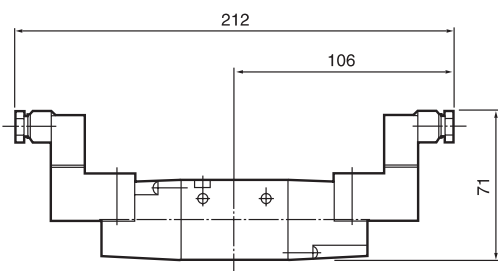

Double solenoid operated

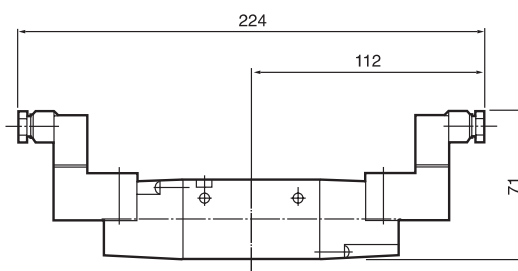

5/3 Body ported
Single solenoid operated air pilot return

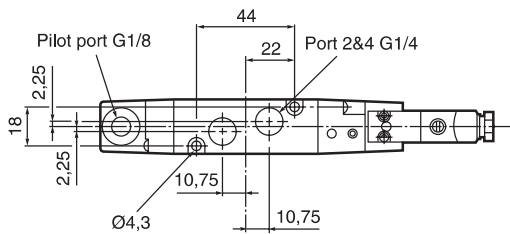
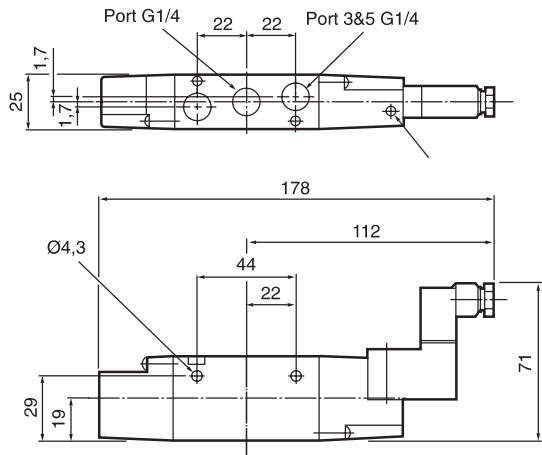

Double solenoid operated

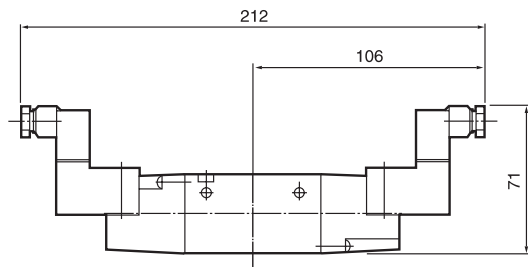

Manifolds

3/2 Inlet Exhaust Manifold
For B4 Body Ported Valves

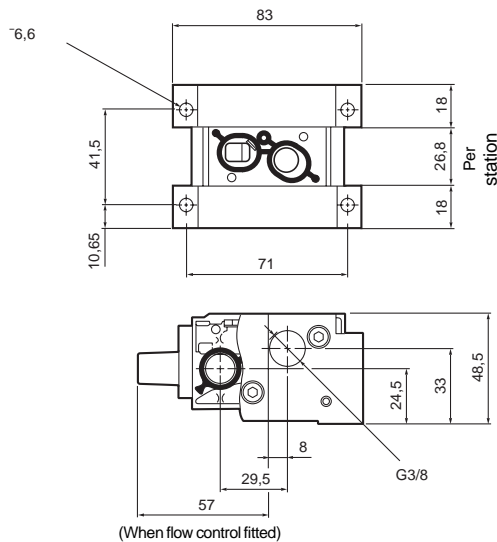

Air pilot type
3/2, Double air pilot operated

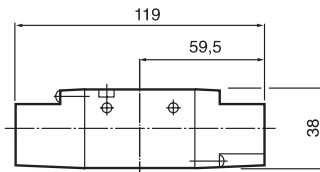

3/2, Air pilot operated air spring return

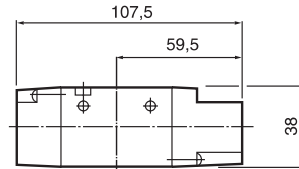

5/2, Double air pilot operated

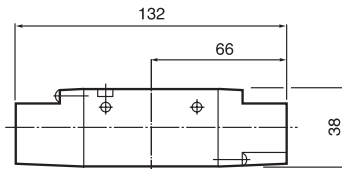

5/2, Air pilot operated air spring return

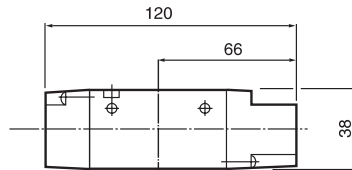

5/3, Double air pilot return

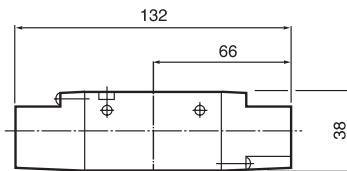

5/2 Inlet Exhaust Manifold
For B4 Body Ported Valves

