

ISOMAX Directional control valves

According to ISO 5599-1

Catalogue PD0C00025UK01-ev

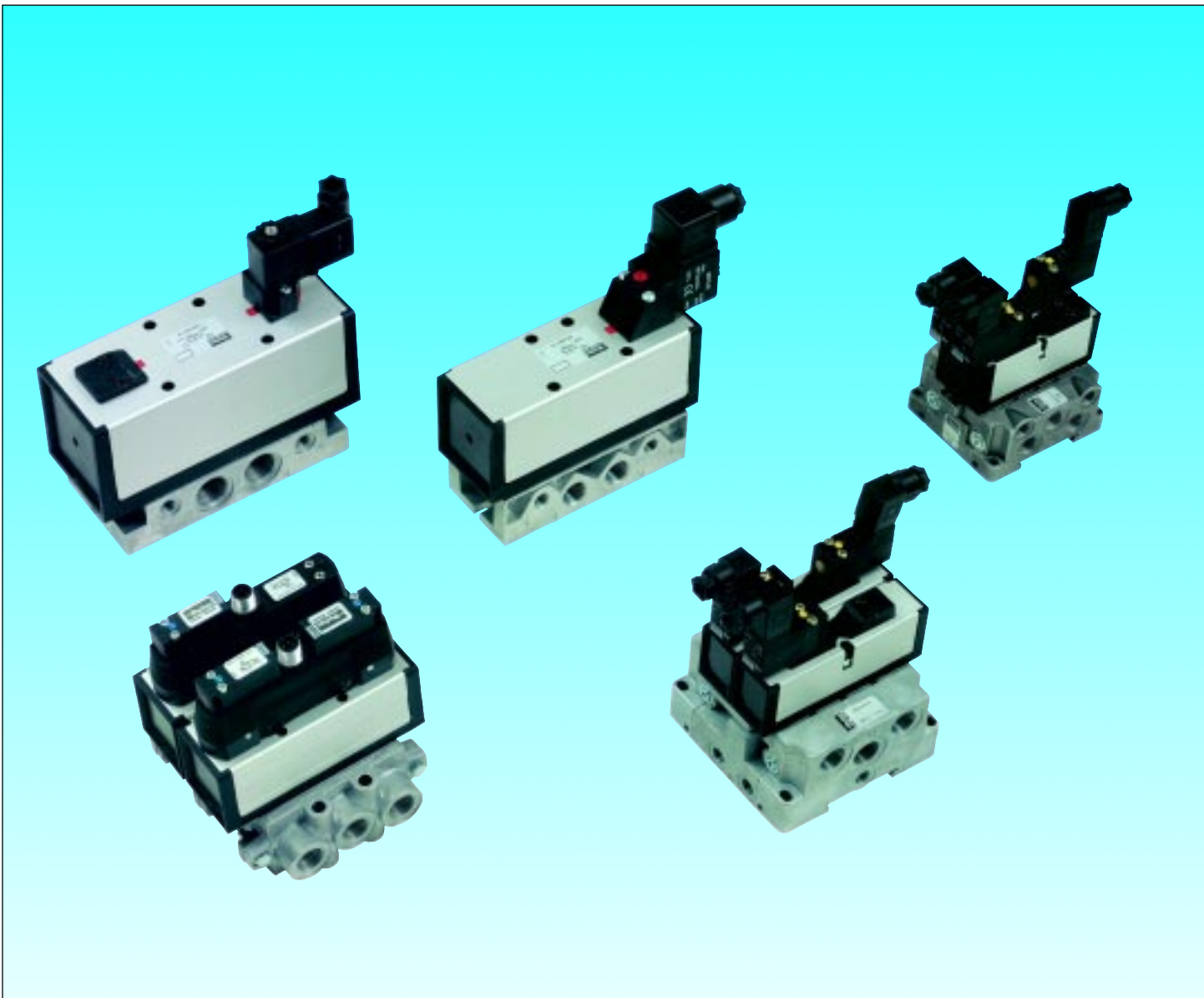

contents

ISO valves sizes 01 to 3 features.....4 - 5

ISO 5599-1 valves sizes 1 to 3

Standard valves technical information.....12

Standard valves order codes.....13 - 14

Solenoid order codes.....15

LOGISO interfaces.....16

Standard valves dimensions.....17

Valves with M12 connector18

Valves with M12 connector order codes19

Valves with M12 connector dimensions19

Base and manifold order codes.....20

Base and manifold accessories.....21

Base and manifold dimensions.....22 - 23

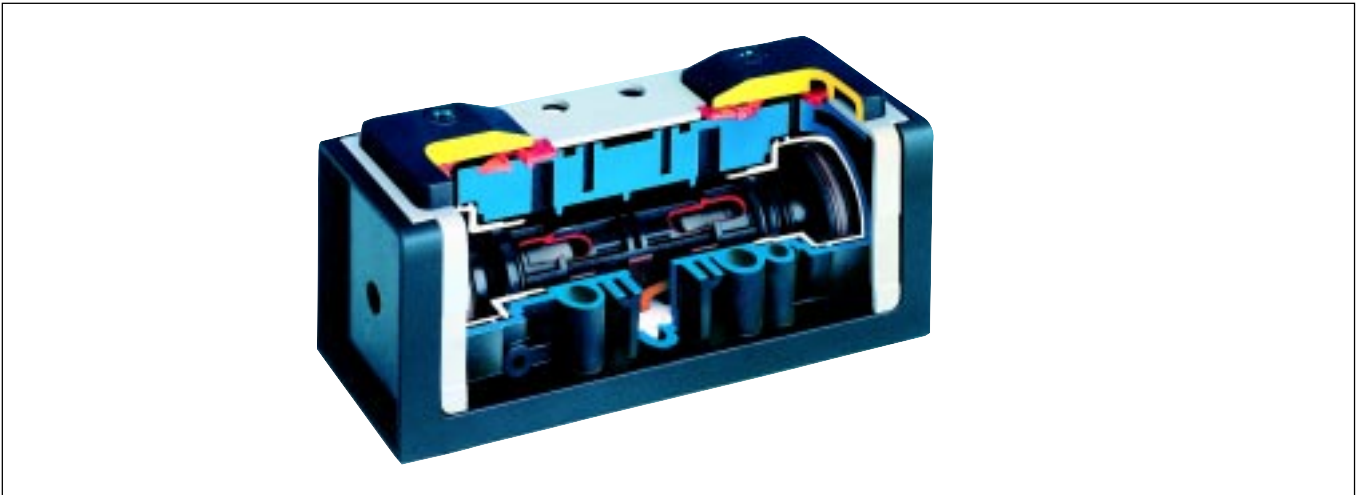

Valve range

DX02 1/8", ISO 15407-1, size 02

DX01 1/4", ISO 15407-1, size 01

DX1 1/4", ISO 5599-1, size 1

DX2 3/8", ISO 5599-1, size 2

DX3 1/2", ISO 5599-1, size 3

The Isomax range of directional control valves, comply with ISO 15407-1 sizes 02 and 01 and ISO5599-1 sizes 1, 2 and 3 and provide flows from 720 NI/min to 6500NI/min.

The range includes both 5/2 and 5/3 valves, for pneumatic and electrical actuation with a wide choice of subbases and manifolds to suit different application needs.



ISO 5599 - 1



ISO 15407 - 1

Ceramic technology

All ISOMAX products use high-tech ceramic switching technology :

- **Excellent reliability :**

Long life in excess of 100 million operations*.

Operates with lubricated or non lubricated air.

Low sensitivity to air quality changes ; switching without seal.

Stiction free.

- **High performances :**

Slide valve concept allows high flow / size ratio and short response time due to short slide stroke and low friction.

- **Stable long lasting performances**

Low friction switching : minimum wear of the valve member/seal assembly.

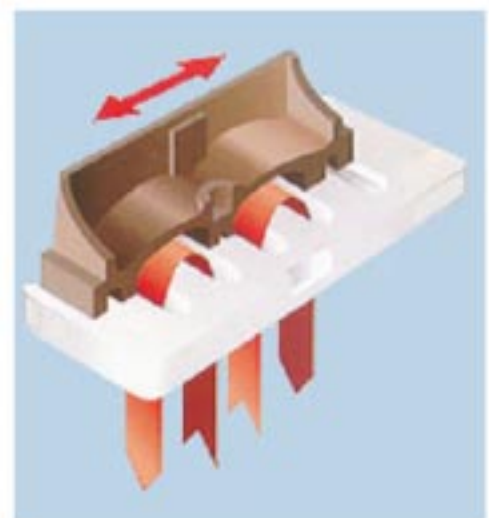

* Refer to our warranty conditions.

Corrosion free and modern design

With the valve body in Polyamide reinforced fibreglass and the casing in anodised aluminium, the complete Isomax range presents a coherent modern design to suit most industrial environments.

Vacuum operation

All Isomax valves may be used for either vacuum or pressure applications.

Air supplied from exhaust ports

In order to supply 2 different pressures to the same actuator, it is possible to connect 2 main pressure supplies to the exhaust ports and used the port 1 as exhaust port.

Central M12 electrical connector versions

All sizes of ISO 5599-1 valves are supplied in a new version with central M12 connector.

Logic elements integrated on valve piloting

Special interfaces for ISOMAX ISO 5599-1 valves are available for direct mounting of logic elements on valve piloting system. This feature allows the creation of complex pilot functions whilst simplifying and reducing piping costs.

Auxiliary manual pilot in option

Manual overrides are supplied as standard on solenoids. An auxiliary manual pilot acting directly on the spool is available as standard on all ISO 5599-1 versions.



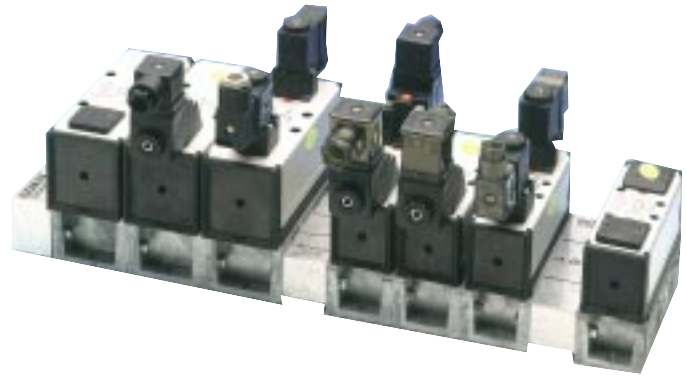

General characteristics :

Standard subbase : ISO 5599-1 and NFE 49-080
 Permissible fluid : Air or inert gas, filtered 40 µ (classe 5 according to ISO 8573-1), lubricated or non-lubricated
 Piloting pressure : 2 to 12 bar (2 to 10 bar with 15 mm solenoid)
 Operating pressure : -0,9 to 12 bar (for pressure under 2 bar, external pilot supply has to be connected)
 Supply from exhaust : Possible
 Flow (Qmax) : DX1 = 1680 NI/mn - DX2 = 4320 NI/mn - DX3 = 6540 NI/mn
 Working temperatures : -10 to + 60°C (dry air)
 Storage temperatures : -20 to + 80°C (-20 to + 70°C with 15 mm solenoids)
 Mechanical life : > 100 millions operations (dry air filtered 40 µ, 2 Hz, 6 bar, 20°C)
 Actuation type : Pneumatically or electrically with CNOMO 06-05-10 solenoids 30 mm or 22 mm or with 15 mm solenoid valve interface CNOMO E06.36120N.

Material specification :

Valve member - seat : Self lubricating acetal - ceramic
 Body : Polyamide reinforced fibreglass
 Casing - End plates : Anodised aluminium - Painted zinc plated steel
 Valve plate : Zamak
 Seals : Nitrile
 Springs : Stainless steel
 Screws : Zinc plated steel
 Function selector : Top cover - Seal : Polyamide reinforced fiberglass - Polyester

Ordering key

Execution	Size	Pilot	Manual override	Voltage	Connector
Standard	1 Size 1 (ISO 5599)	4 Pneumatic	0 Without any	B 12 V AC	Without any
D Anti-corrosion	2 Size 2 (ISO 5599)	6 Electro-pneumatic	1 Flush non locking	C 24 V AC	C Standard connector
	3 Size 3 (ISO 5599)		3 Flush locking	D 48 V AC	S Connector with LED and protection
				J 110 V AC	S3 Connector with LED and protection - 3 m cable
				A 230 V AC	S5 Connector with LED and protection - 5 m cable
				L 12 V DC	
				M 24 V DC	
				N 48 V DC	

DX **1** - **6** **21** - **76** **1** **M** **S**

Function	pneumatic or electro-pneu		electro-pneumatic		pneumatic and electro-pneu	
	int. supply	ext. supply	int. supply 12 ext. supply 14	int. supply 12 ext. supply 14	solenoid on 14	solenoid on 12
	captured pilot exhaust	vented pilot exhaust	vented pilot exhaust	vented pilot exhaust	vented pilot exhaust	vented pilot exhaust
5/2 bistable	06	08	07	31	33	
5/2 bistable, 14 prioritised	56	58				
5/2 monostable, spring return	21	22				
5/2 monostable, differential return	51	53	52			
5/3 pressure vented centre	11	12	10			
5/3 pressure closed centre	16	18	17			
5/3 pressurised centre	13	24	15			

Electrical operator, auxiliary manual pilot		
	electrical operator	aux. manual. pilot
60	Without any	No
61	EV 310	
66	EV 30 - 6.5 W	
67	EV 30 - 3 W	
6A	15 mm solenoid, individual plate, pin up	
6B	15 mm solenoid, individual plate, pin up (high flow)	
70	Without any	Yes
71	EV 310	
76	EV 30 - 6.5 W	
77	EV 30 - 3 W	
7A	15 mm solenoid, individual plate, pin up	
7B	15 mm solenoid, individual plate, pin up (high flow)	

= product available on special request

Order codes

Pneumatically actuated valves

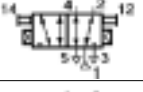
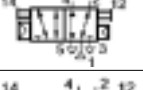
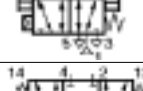
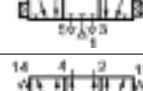
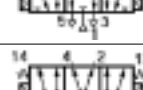
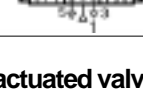
Symbol	Function	ISO 5599-1 size	Order code	Weight kg
	5/2 Bistable	1	DX1-406-70	0,35
		2	DX2-406-70	0,60
		3	DX3-406-70	1,10
	5/2 Monostable differential	1	DX1-451-70	0,35
		2	DX2-451-70	0,60
		3	DX3-451-70	1,10
	5/2 Monostable spring	1	DX1-421-70	0,35
		2	DX2-421-70	0,60
		3	DX3-421-70	1,10
	5/3 closed centre	1	DX1-416-70	0,35
		2	DX2-416-70	0,60
		3	DX3-416-70	1,10
	5/3 vented centre	1	DX1-411-70	0,35
		2	DX2-411-70	0,60
		3	DX3-411-70	1,10
	5/3 pressurised centre	1	DX1-413-70	0,35
		2	DX2-413-70	0,60

Electrically actuated valves for CNOMO 06-05-10 solenoid supplied without solenoid - Refer to page 15 to select solenoid

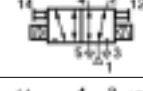
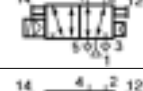
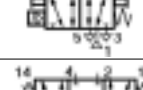
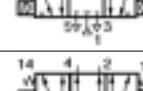
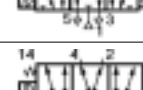
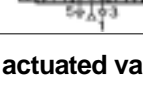

	Bistable	1	DX1-606-70	0,35
		2	DX2-606-70	0,60
		3	DX3-606-70	1,10
	5/2 Monostable differential	1	DX1-651-70	0,35
		2	DX2-651-70	0,60
		3	DX3-651-70	1,10
	5/2 Monostable spring	1	DX1-621-70	0,35
		2	DX2-621-70	0,60
		3	DX3-621-70	1,10
	5/3 closed centre	1	DX1-616-70	0,65
		2	DX2-616-70	0,60
		3	DX3-616-70	1,10
	5/3 vented centre	1	DX1-611-70	0,35
		2	DX2-611-70	0,60
		3	DX3-611-70	1,10
	5/3 pressurised centre	1	DX1-613-70	0,35
		2	DX2-613-70	0,60

Electrically actuated valves for 15 mm solenoid supplied without solenoid - Refer to page 15 to select solenoid

	Bistable	1	DX1-606-7B	0,37
		2	DX2-606-7B	0,60
		3	DX3-606-7B	1,10
	5/2 Monostable differential	1	DX1-651-7B	0,36
		2	DX2-651-7B	0,60
		3	DX3-651-7B	1,10
	5/2 Monostable spring	1	DX1-621-7B	0,36
		2	DX2-621-7B	0,60
		3	DX3-621-7B	1,10
	5/3 closed centre	1	DX1-616-7B	0,37
		2	DX2-616-7B	0,60
		3	DX3-616-7B	1,10
	5/3 vented centre	1	DX1-611-7B	0,37
		2	DX2-611-7B	0,60
		3	DX3-611-7B	1,10
	5/3 pressurised centre	1	DX1-613-7B	0,37
		2	DX2-613-7B	0,60

Order codes

Electrically actuated valves with CNOMO 06-05-10 30 mm solenoid 24 V DC (supplied without cable plug) ;

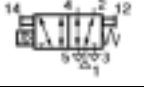
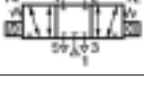
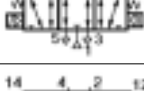
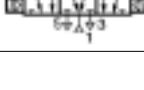



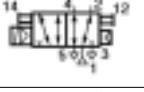
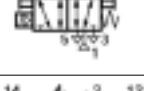
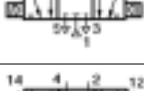
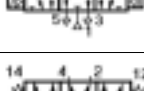
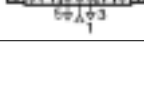



Symbol	Function	ISO 5599-1 size	Order code	Weight kg
	Bistable	1	DX1-606-761M	0,65
		2	DX2-606-761M	0,90
		3	DX3-606-761M	1,40
	5/2 Monostable differential	1	DX1-651-761M	0,50
		2	DX2-651-761M	0,75
		3	DX3-651-761M	1,25
	5/2 Monostable spring	1	DX1-621-761M	0,50
		2	DX2-621-761M	0,75
		3	DX3-621-761M	1,25
	5/3 closed centre	1	DX1-616-761M	0,35
		2	DX2-616-761M	0,90
		3	DX3-616-761M	1,40
	5/3 vented centre	1	DX1-611-761M	0,65
		2	DX2-611-761M	0,90
		3	DX3-611-761M	1,40
	5/3 pressurised centre	1	DX1-613-761M	0,65
		2	DX2-613-761M	0,90

Electrically actuated valves with 15 mm solenoid 24 V DC (supplied without cable plug) ;



Symbol	Function	ISO 5599-1 size	Order code	Weight kg
	Bistable	1	DX1-606-7B1M	0,45
		2	DX2-606-7B1M	0,70
		3	DX3-606-7B1M	1,20
	5/2 Monostable differential	1	DX1-651-7B1M	0,41
		2	DX2-651-7B1M	0,65
		3	DX3-651-7B1M	1,15
	Monostable spring	1	DX1-621-7B1M	0,41
		2	DX2-621-7B1M	0,65
		3	DX3-621-7B1M	1,15
	5/3 closed centre	1	DX1-616-7B1M	0,45
		2	DX2-616-7B1M	0,70
		3	DX3-616-7B1M	1,20
	5/3 vented centre	1	DX1-611-7B1M	0,45
		2	DX2-611-7B1M	0,70
		3	DX3-611-7B1M	1,20
	5/3 pressurised centre	1	DX1-613-7B1M	0,45
		2	DX2-613-7B1M	0,70

Note : all valves proposed in this page are supplied with non-locking manual override on the solenoids ; to obtain the same valves with locking manual override change the last digits of the order code from 1M to 3M.

Solenoids

		Voltage	Weight kg	Order code Without manual override	Order code Manual override non locking	Order code Manual override locking
EV30-6.5 W solenoids with CNOMO 06-05-10 interface and for cable plug DIN 43650 form A (supplied without cable plug)						
		24 V DC	0,17	EV30M0100	EV30M1100	EV30M3100
		24 V AC	0,17	EV30C0100	EV30C1100	EV30C3100
		110 V AC	0,17	EV30J0100	EV30J1100	EV30J3100
		230 V DC	0,17	EV30A0100	EV30A1100	EV30A3100
EV30-3 W solenoids with CNOMO 06-05-10 interface and for cable plug DIN 43650 form A (supplied without cable plug)						
		24 V DC	0,17	EV30M0200	EV30M1200	EV30M3200
		24 V AC	0,17	EV30C0200	EV30C1200	EV30C3200
		110 V AC	0,17	EV30J0200	EV30J1200	EV30J3200
		230 V AC	0,17	EV30A0200	EV30A1200	EV30A3200
EV310-3W solenoids with CNOMO 06-05-10 interface and for cable plug DIN 43650 form B (supplied without cable plug)						
		24 V DC	0,17	EV0M310	1EV1M310	EV3M310
		24 V AC	0,17	EV0C310	1EV1C310	EV3C310
		110 V AC	0,17	EV0J310	1EV1J310	EV3J310
		230 V AC	0,17	EV0A310	1EV1A310	EV3A310
15 mm High-flow solenoids 1.8 W for cable plug DIN 43650 form C (supplied without cable plug)						
		24 V DC	0,17	P2E- HV32C0	P2E-HV32C1	P2E-HV32C2
		24 V AC	0,17	P2E-HV31C0	P2E-HV31C1	P2E-HV31C2
		48 V DC	0,17	P2E-HV32D0	P2E-HV32D1	P2E-HV32D2
		115/120 V AC	0,17	P2E-HV31F0	P2E-HV31F1	P2E-HV31F2

Cable plugs

Description	Order code DIN 43650 form A (for EV30)	Order code DIN 43650 form B (for EV310)	Order code DIN 43650 form C (for 15 mm solenoid)	
	- Standard (without flying lead)	3EV290V10	3EV10V10	P8C-D
	- With LED and protection 24 V AC/DC	3EV290V20-24	3EV10V20-24	P8C-D26C
	- With LED and protection 110 V AC	3EV290V20-110	3EV10V20-110	P8C-D21E
	- With LED and protection 230 V AC	3EV290V20-230	3EV10V20-230	-
	- With 5 m flying lead cable LED and protection 24 V AC/DC	3EV290V20-24L5	3EV10V20-24L5	P8L-C526C
	- With 5 m cable - LED and protection 110 V AC	3EV290V20-110L5	3EV10V20-110L5	P8L-C521E
	- With 5 m cable - LED and protection 230 V AC	3EV290V20-230L5	3EV10V20-230L5	-

LOGISO interfaces

Logiso interfaces allow direct mounting of logic elements on Isomax valves sizes 1 to 3 ; it allows to create simple solution on creating complex valve pilot function : low pressure or high pressure signal, delayed pilot signal, or control of alternating movement, etc....

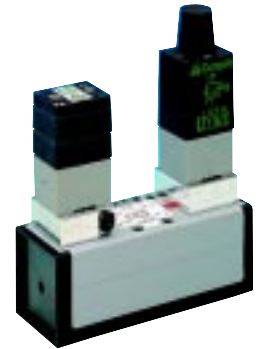

Symbol	Function	Order code	Weight kg
--------	----------	------------	-----------

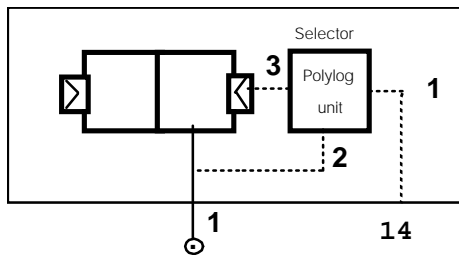

Port 1 (input signal 1 for logic element) is connected to pilot port 12 or 14 valves subbase.

Port 2 (input signal 2 for logic element) is connected to the internal air supply of the valve.

38DX70 0,05

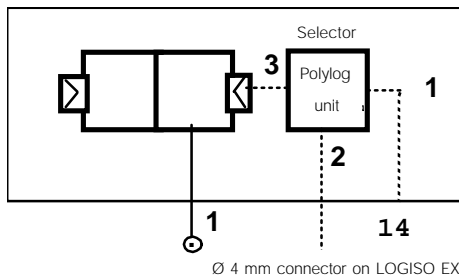

Port 1 (input signal 1 for logic element) is connected to pilot port 12 or 14 valves subbase.

Port 2 (input signal 2) for logic element is connected to the external Ø 4 mm push-in fitting.

34DX70 0,25

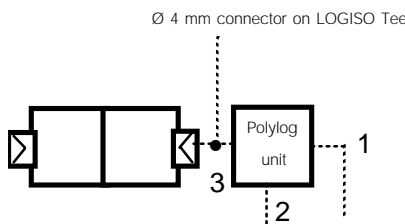

Use to tee off output (port 3) of the logic unit. Has to be mounted in association with Logiso IN or Logiso Ex interfaces for use with logic elements.

33DX70 0,05

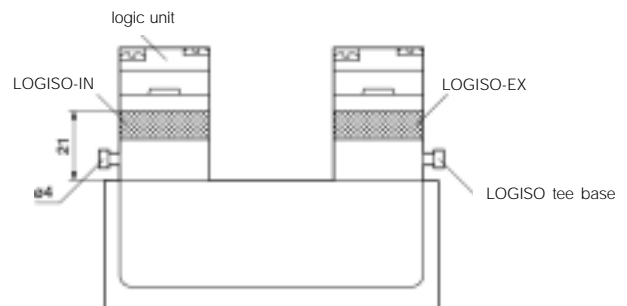
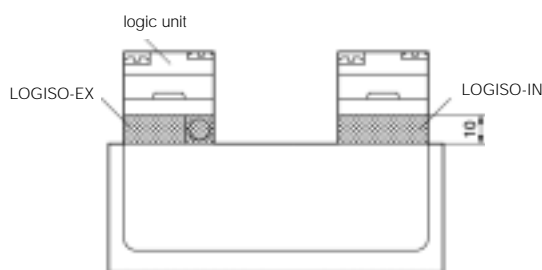

Dimensions

Pneumatically actuated

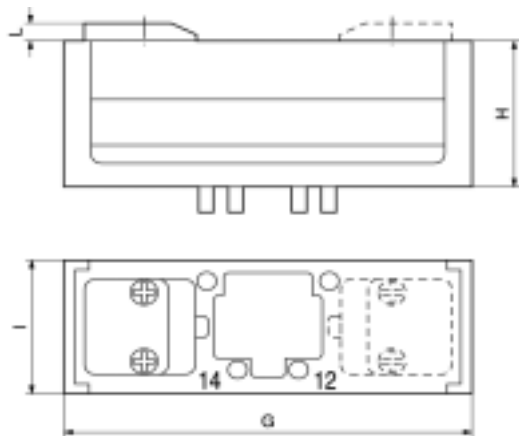

With EV30 solenoids

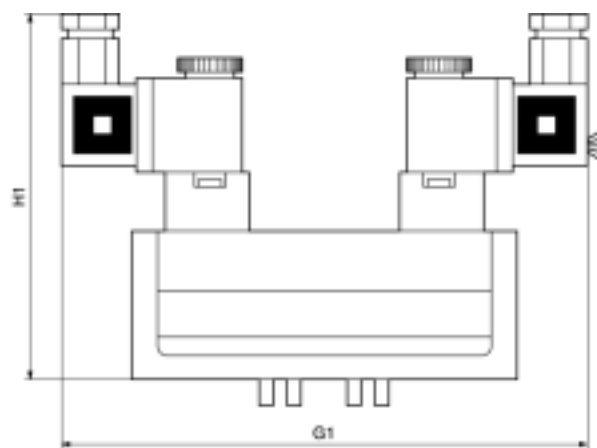

With EV310 solenoids

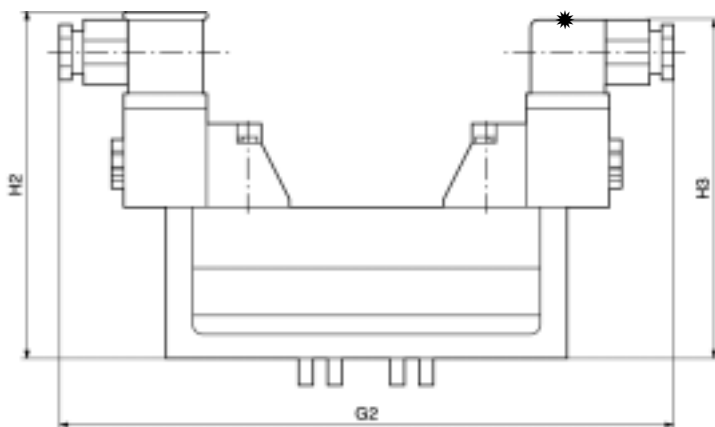

With 15 mm solenoids

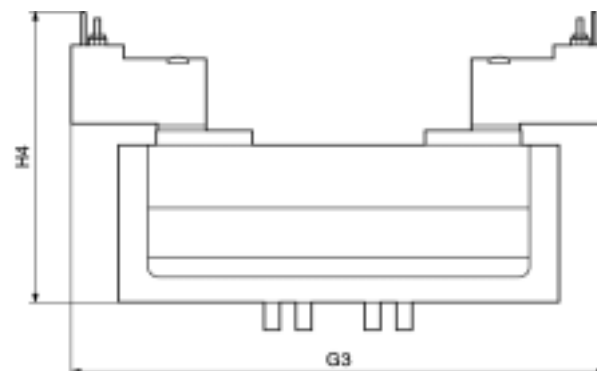

	G	G1	G2	G3	H	H1	H2	H3	H4	I	L
DX1	120	164	202,5	160	47	115	112,5	119	79	42	5
DX2	140	179,5	218	175,5	58,5	126,5	126,5	130	90,5	54	5
DX3	170	198	235,5	194	71	139	139	142,5	103	68	5



General characteristics :

Standard subbase :	ISO 5599-1 and NFE 49-080
Permissible fluid :	Air or inert gas, filtered 40 µ (classe 5 according to ISO 8573-1), lubricated or non-lubricated
Piloting pressure :	2 to 10 bar
Operating pressure :	-0,9 to 10 bar (for pressure under 2 bar, external pilot supply has to be connected)
Supply from exhaust :	Possible
Flow (Qmax) :	DX1 = 1680 NI/mn - DX2 = 4320 NI/mn - DX3 = 6540 NI/mn
Working temperatures :	-10 to + 60°C (dry air)
Storage temperatures :	-20 to + 70°C
Mechanical life :	> 100 millions operations (dry air filtered 40 µ, 2 Hz, 6 bar, 20°C)
Actuation type :	Electrically
Voltage :	24 V DC
Electrical connections :	Central M12 connector (according to norm E03.62.520N) with 4 pins Pin 1 : free Pin 2 : +24 V DC side 12 Pin 3 : 0 V common Pin 4 : + 24 V DC side 14
Dust and water protection :	IP 65 (according to EN 60529)
Pilot power consumption :	1,8 W per pilot
Solenoid actuation indication :	By green LED
Manual override :	Locking or non locking on the solenoids (version without manual override on request)

Material specification :

Valve member - seat :	Self lubricating acetal - ceramic
Body :	Polyamide reinforced fibreglass
Casing - End plates :	Anodised aluminium - Painted zinc plated steel
Valve plate :	Zamak
Seals :	Nitrile
Springs :	Stainless steel
Screws :	Zinc plated steel
Function selector : Top cover - Seal :	Polyamide reinforced fibreglass - Polyester

Ordering key

Execution	Size	Pilot	Manual override	Voltage	Connector
Standard	1 Size 1 (ISO 5599) 2 Size 2 (ISO 5599) 3 Size 3 (ISO 5599)	6 Electro-pneumatic	0 Without any 1 Flush non locking 3 Flush locking 2 Flush non locking (extended 15 mm) 5 Flush locking (extended, 15 mm)	M 24 V DC	A M12 connector (5° oriented, 12 side) B M12 connector (22,5° oriented, 14 side)

DX

1
-
6
21
-
96
1
M
B

Function	electro-pneumatic			
	int. supply	ext. supply by 12 and 14	ext. supply by 14	int. supply 12 ext. supply 14
5/2 bistable	06	08	61	07
5/2 bistable, 14 prioritised	56	58	62	
5/2 monostable, spring return	21	22		
5/2 monostable, differential return	51	53	63	52
5/3 pressure vented centre	11	12	64	10
5/3 pressure closed centre	16	18	65	17
5/3 pressurised centre	13	14	66	15

Electrical operator, auxiliary manual pilot on spool		
	electrical operator	aux. manual. pilot
96	15 mm solenoid 1,8 W (high flow)	No

= product available on special request

Order codes

Manual override non-locking ; internal pilot supply

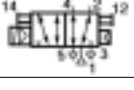
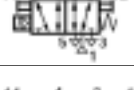
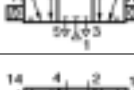
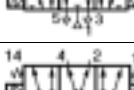
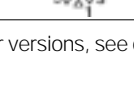
Symbol	Function	ISO 5599-1 Size	Order code	Weight	Order code	Weight
			with M12 5° oriented side 12	kg	with M12 22,5° oriented side 14	kg
	Bistable	1	DX1-606-961MA	0,50	DX1-606-961MB	0,50
		2	DX2-606-961MA	0,74	DX2-606-961MB	0,74
		3	DX3-606-961MA	1,30	DX3-606-961MB	1,30
	5/2 Monostable differential	1	DX1-651-961MA	0,47	DX1-651-961MB	0,47
		2	DX2-651-961MA	0,70	DX2-651-961MB	0,70
		3	DX3-651-961MA	1,25	DX3-651-961MB	1,25
	5/2 Monostable spring	1	DX1-621-961MA	0,47	DX1-621-961MB	0,47
		2	DX2-621-961MA	0,70	DX2-621-961MB	0,70
		3	DX3-621-961MA	1,25	DX3-621-961MB	1,25
	5/3 closed centre	1	DX1-616-961MA	0,50	DX1-616-961MB	0,50
		2	DX2-616-961MA	0,74	DX2-616-961MB	0,74
		3	DX3-616-961MA	1,30	DX3-616-961MB	1,30
	5/3 vented centre	1	DX1-611-961MA	0,50	DX1-611-961MB	0,50
		2	DX2-611-961MA	0,74	DX2-611-961MB	0,74
		3	DX3-611-961MA	1,30	DX3-611-961MB	1,30
	5/3 pressurised centre	1	DX1-613-961MA	0,50	DX1-613-961MB	0,50
		2	DX2-613-961MA	0,74	DX2-613-961MB	0,74

Note : for all other versions, see ordering key page 18

Dimensions

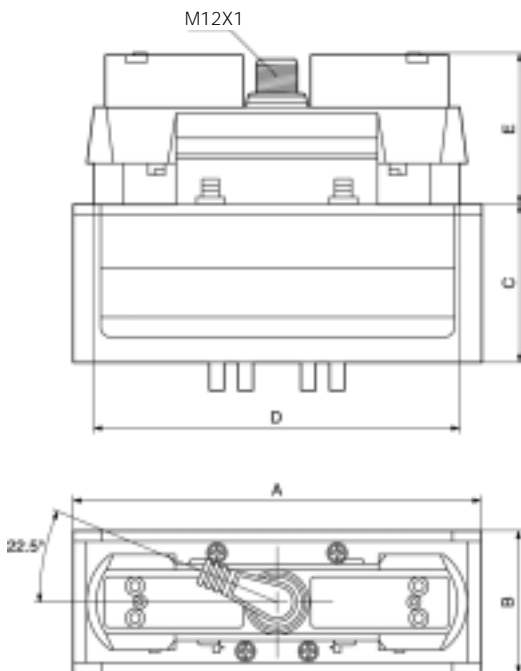





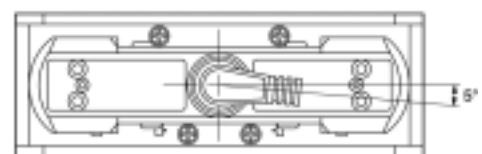

	A	B	C	D	E*
DX1	120	42	47	108	44
DX2	140	54	58,5	114	44
DX3	170	68	71	132	44

* For version with external pilot supply common by 14, add 6 mm.

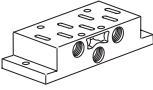









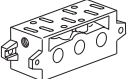

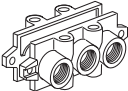
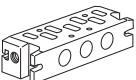

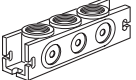
Manifolds and subbases

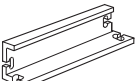
Single subbases

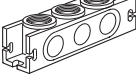
		Description	Order code	Weight kg	Port size
		Subbase with side ports according to VDMA			
		Size 1	P2N-VS512SD	0,16	G1/4
		Size 2	P2N-WS513S	0,28	G3/8
		Size 3	P2N-YS514SD	0,35	G1/2
		Subbase with side ports			
		Size 1	PL1-1/4-70	0,16	G1/4
		Size 2	PL2-3/8-70	0,28	G3/8
		Size 3	P2N-JS516SD	0,57	G3/4
		Subbase with bottom ports			
		Size 1	PD1-1/4-70	0,37	G1/4
		Size 2	PD2-3/8-70	0,59	G3/8
		Size 3	PD3-1/2-70	0,90	G1/2

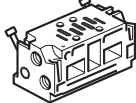
Manifolds

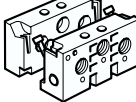
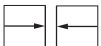
		Description	Order code	Weight kg	Port size
		Manifold with bottom ports according to VDMA			
		Size 1	P2N-VM512MB	0,24	G1/4
		Size 2	P2N-WM513MB	0,36	G3/8
		Size 3	P2N-YM514MB	0,70	G1/2
		End plate kit for above bottom ported manifold according to VDMA			
		Size 1	P2N-VM513E	0,21	G3/8
		Size 2	P2N-WM514ES	0,36	G1/2
		Size 3	P2N-YM518ES	0,68	G1
		Manifold with bottom ports low profile			
		Size 1	P2N-AM512MB	0,20	G1/4
		Top or bottom ported connecting block for above manifold "low profile"			
		Size 1	P2N-AM513GT	0,15	G3/8
		End piece for above manifold "low profile"			
		Size 1	P2N-AM500J	0,06	
		Top or bottom ported intermediate supply for above manifold "low profile"			
		Size 1	P2N-AM513BT	0,14	G3/8
		Isolating seal for above manifold "low profile"			
		Size 1	P2N-AK0P	0,07	
		Manifold with side port			
		Size 1	P2N-EM512MD	0,24	G1/4
		Size 2	P2N-FM513MD	0,36	G3/8
		Side ported connecting kit for above manifold with side ports			
		Size 1	P2N-EM513ES	0,21	G3/8
		Size 2	P2N-FM514ES	0,29	G1/2

Manifolds and subbases accessories

Order codes

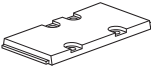
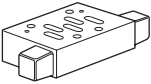
	Description	Order code	Weight kg
	Blanking plate		
	Size 1	P2N-AA5B	0,10
	Size 2	P2N-BA5B	0,15
	Size 3	P2N-CA5B	0,20
	Sandwich flow control interface function plate (for exhaust flow control - adjustment by hex. Key)		
	Size 1	P2N-GA5F	0,22
	Size 2	P2N-HA5F	0,35
	Size 3	P2N-JA5F	0,86

Dimensions

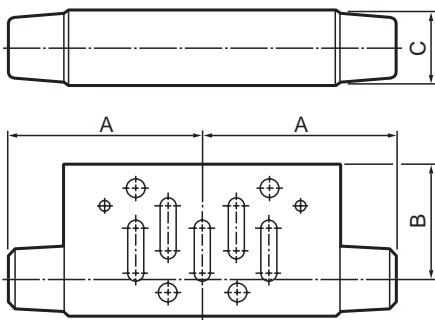

	ISO size	A	B	C	D
P2N-GA5F	1	51	30	20	89
P2N-HA5F	2	67	25	26	108
P2N-JA5F	3	89	33,5	33	122

Manifold and end plates according to VDMA (P2N-VM / WM / YM)

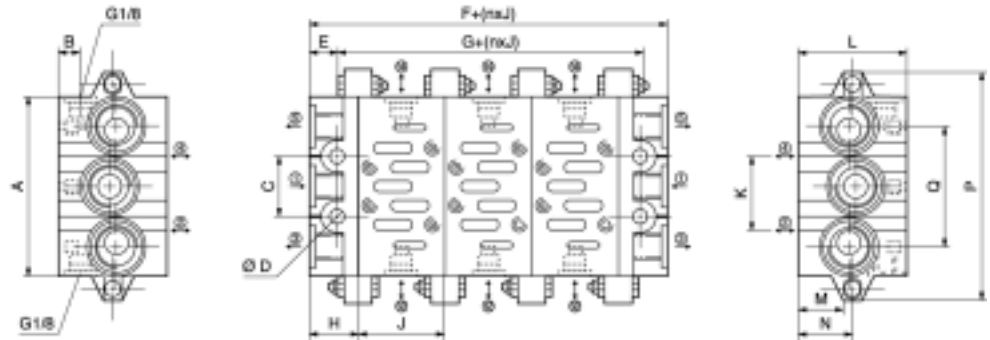

ISO Size	Port 1, 3, 5	Port 2, 4	A	B	C	D	E	F	G	H	J	K	L	M	N	O	P
1	G3/8	G1/4	85	8,5	28	7	11	44	22	22	43	26	46	21	24	56	110
2	G1/2	G3/8	100	9	35	9	13	52	26	26	56	30	47	22	24	68	135
3	G1	G1/2	140	10	52	12	15	60	30	30	71	38	56	31	34	104	190

Manifold and end plates with bottom ports "low profile" (P2N-AM..)

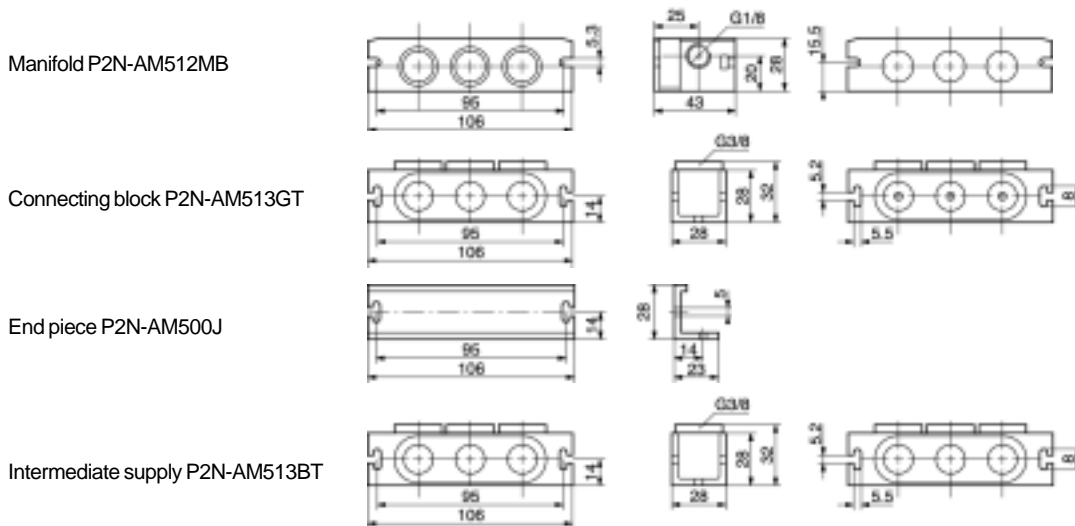

Manifold and end plates with side ports (P2N-EM / FM..)

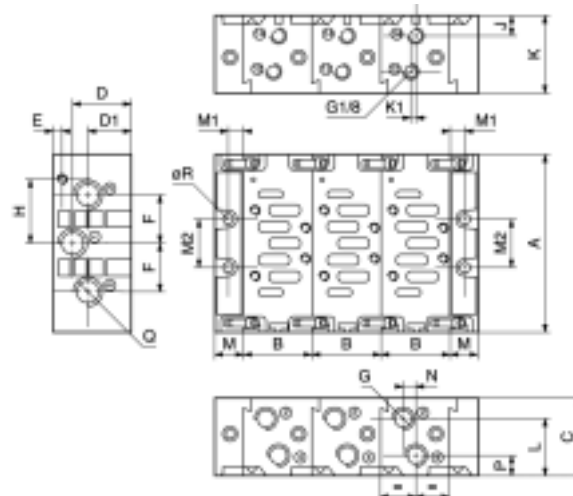

Order code	A	B	C	D	D1	E	F	G	H	J	K	K1	L	M	M1	M2	N	P	Q	R
P2N-EM ...	110	43	48	35,5	26,5	5,5	28	G1/4	36	15,5	35	3	32	20	11	28	12	12,5	G3/8	6
P2N-FM ...	129	56	60	44,5	35,5	6	34,5	G3/8	45	16	41,5	3	41	24	13	35	12,5	16	G1/2	8