



# *Directional Control Valves*

*G<sup>1</sup>/<sub>8</sub>, 3/2 Poppet Valves*

*Catalogue no: 2132GB-ca*



# Poppet valves G<sup>1/8</sup>

## Midget poppet valves

Combining, versatility, compactness and the rugged design characteristics of the poppet mechanism. This range of poppet valves, provides units that are light to operate and give long and trouble free operational life.

The body is a block-form die-casting in zinc. The poppet mechanism uses a nylon ball and a synthetic rubber 'O' ring as the main seat and seal respectively, the exhaust seal is of 'U' cup form, working with a stainless steel plunger. All the valves are greased during assembly, they will run for long periods without further lubrication.

Designed for use with air, the small poppet area requires only a light force to operate any of the valves, a factor particularly useful in the mechanically operated types, other available actuators cover the automatic and manual operation. The return mechanism after actuation is by spring on all valves in the range.

## Features

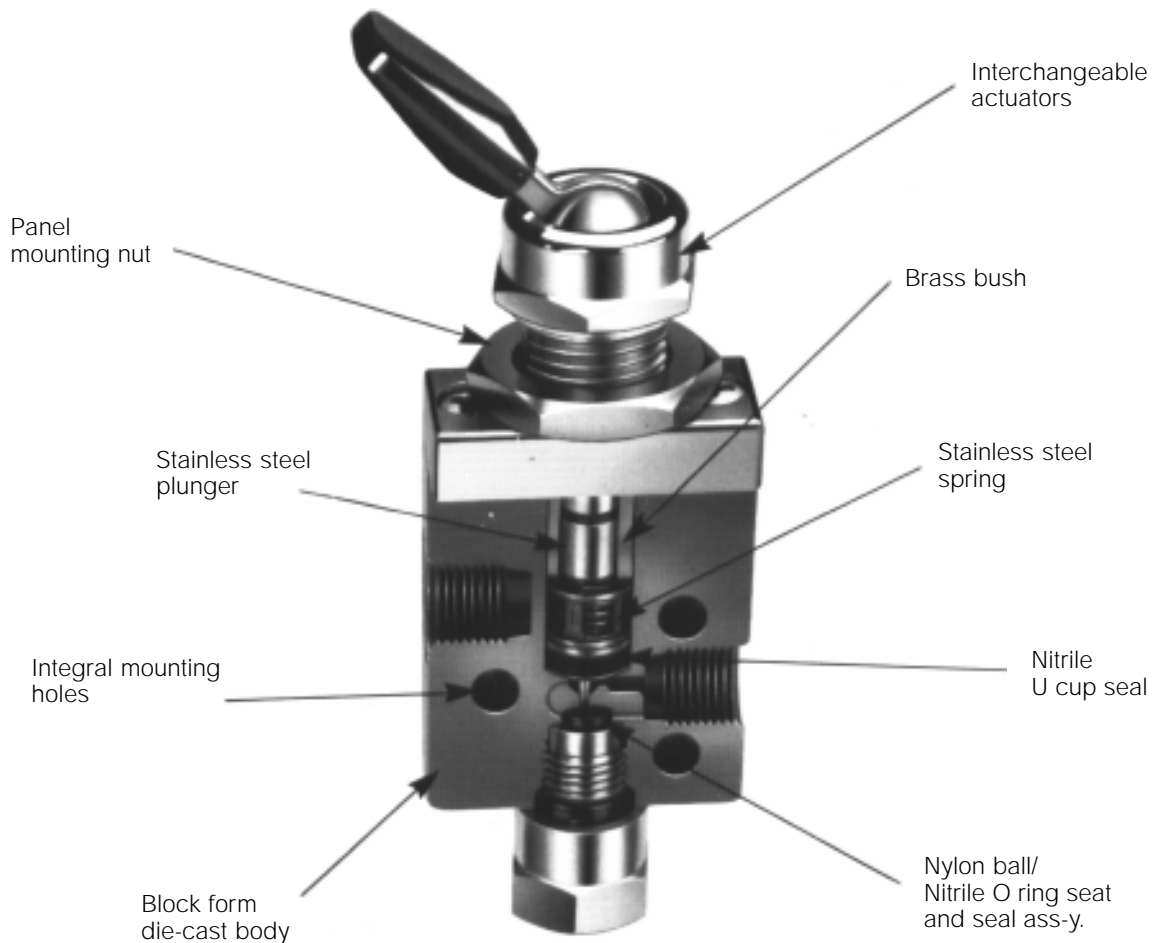

## Basic body dimensions (mm)

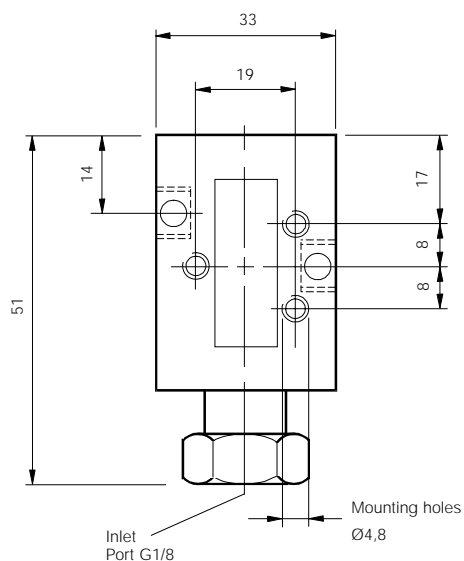

## Repair kits

Description	Part no.
Mechanically, manually and air pilot operated valves	<b>43608</b>
Diaphragm operated valves.	<b>43608B</b>

## Lubricating oils

To ensure long life and trouble free service from valves, it is recommended the equipment should be adequately lubricated by means of lubricators which disperse oil into the system. Only paraffinic based oils can be used, and the following recommendations are given as a general guide to types of oil that are suitable for use with Parker airline equipment.

The list opposite does not preclude the use of oils manufactured by other companies but oils must be paraffinic based.

As a general guide, lubricator drip rates should be 1 drip/minute for every 5 litre/second (10 cubic feet per minute) passed through the equipment.

Oil company	Grade	Viscosity
Century oils	P.W.L.A	32
Alexander Duckham	Zircon 4	32
Gulf oil (GB) Limited	Harmony 43 AW	32
Shell (UK) oil	Tellus 37	37
Burmah Castrol	Hyspin AWS 32	32
Edgar Vaughan	Y Hydrodrive HP 100	32
Esso Petroleum	Nuto H32	32
B.P.	HLP 32	32
Mobil Oil Company	DTE Oil - Light	32
Motul	VPI-A	32
Silkolene	Derwent 32	32

# Poppet valves G<sup>1</sup>/<sub>8</sub>

## Air pilot and diaphragm operated



## Symbol

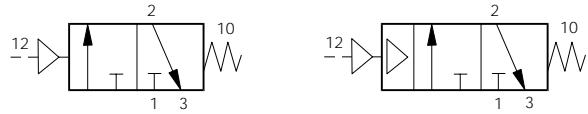

## Materials

Body	Zinc diecast
Stem	Stainless steel
Spring housing	Aluminium
Seals	Nitrile
Spring	Stainless steel

## Technical information

Type	Poppet valve
Style	Body ported
Port size	G <sup>1</sup> / <sub>8</sub>
Mounting	Any plane
Temperature range	-10°C to +80°C

## Pneumatic information

Pressure range	0 to 10 bar
Minimum pilot pressure	0,8 bar
Minimum dia. pressure	0,14 bar
Nominal Ø	3,2mm
Nominal flow at 7 bar	3,7 dm <sup>3</sup> /sec
Cv factor	0,175

## Ordering information

Part nos.	Actuator	Symbol
<b>B43603P</b>	Air pilot	
<b>B43603D</b>	Diaphragm	

## Air pilot operated dimensions (mm)

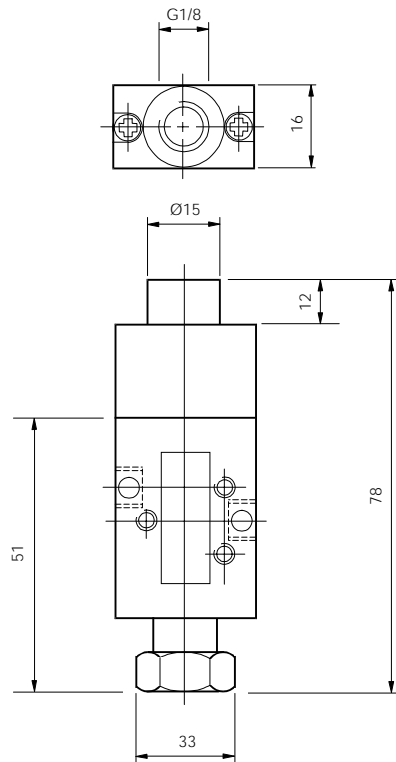

## Diaphragm operated dimensions (mm)

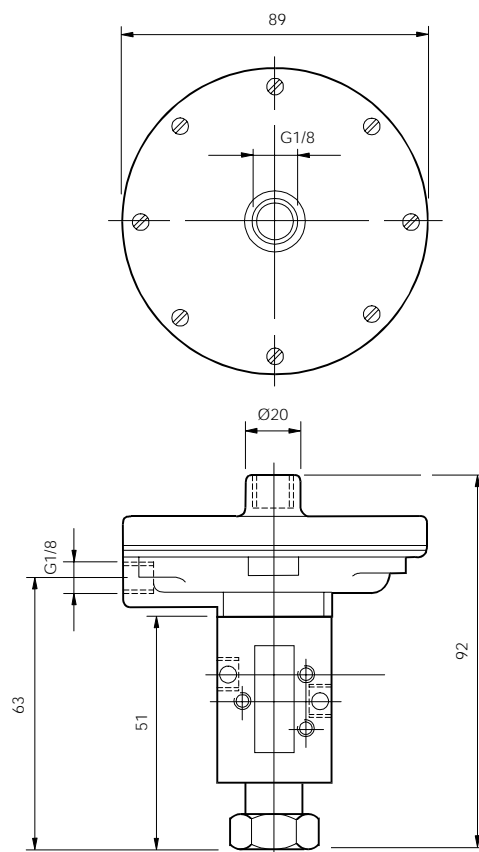

# Poppet valves G<sup>1</sup>/<sub>8</sub>

## Mechanically operated valves

## Symbol

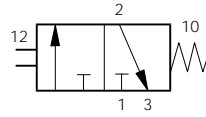

## Materials

Body	Zinc diecast
Stem	Stainless steel
Spring housing	Aluminium
Seals	Nitrile
Spring	Stainless steel

## Technical information

Type	Poppet valve
Style	Body ported
Port size	G <sup>1</sup> / <sub>8</sub>
Mounting	Any plane
Temperature range	-10°C to +80°C

## Pneumatic information

Pressure range	0 to 10 bar
Minimum pilot pressure	0,8 bar
Minimum dia. pressure	0,14 bar
Nominal Ø	3,2mm
Nominal flow at 7 bar	3,7 dm <sup>3</sup> /sec
Cv factor	0,175

## Ordering information

Part nos.	Actuator	Symbol	Operating force
<b>B43603C</b>	Plunger		11 N
<b>B43603R</b>	Roller		6 N
<b>B43603RT</b>	One way roller trip		6 N
<b>B43603T</b>	One way trip		6 N



# Poppet valves G<sup>1</sup>/<sub>8</sub>

## Manually operated valves



## Symbol

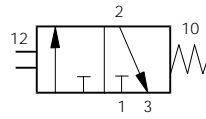

## Materials

Body	Zinc diecast
Stem	Stainless steel
Spring housing	Aluminium
Seals	Nitrile
Spring	Stainless steel

## Technical information

Type	Poppet valve
Style	Body ported
Port size	G <sup>1</sup> / <sub>8</sub>
Mounting	Any plane
Temperature range	-10°C to +80°C

## Pneumatic information

Pressure range	0 to 10 bar
Minimum pilot pressure	0,8 bar
Minimum dia. pressure	0,14 bar
Nominal Ø	3,2mm
Nominal flow at 7 bar	3,7 dm <sup>3</sup> /sec
Cv factor	0,175

## Ordering information

Part nos.	Actuator	Symbol	Operating force
<b>B43603B</b>	Button		11 N
<b>B43603E</b>	Palm lever		5 N
<b>B43603L</b>	Lock down lever		5 N
<b>B43603F</b>	Foot		10 N

### Button colours

Black : X

Red : Y

Green : Z

Add suffix to part no.

# Poppet valves G<sup>1</sup>/<sub>8</sub>

## Button operated

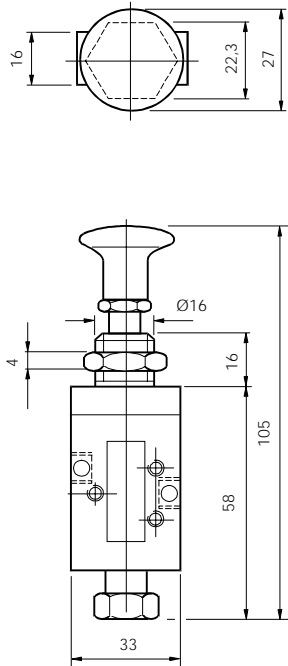

## Lock down lever operated

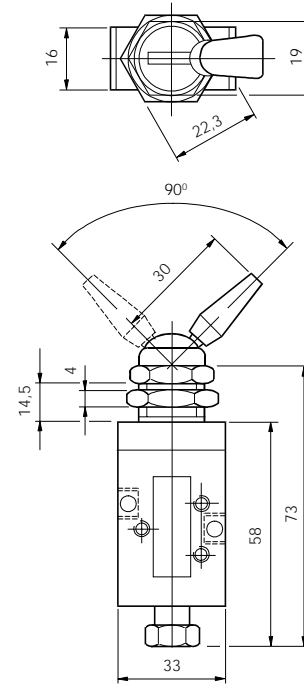

## Palm lever operated

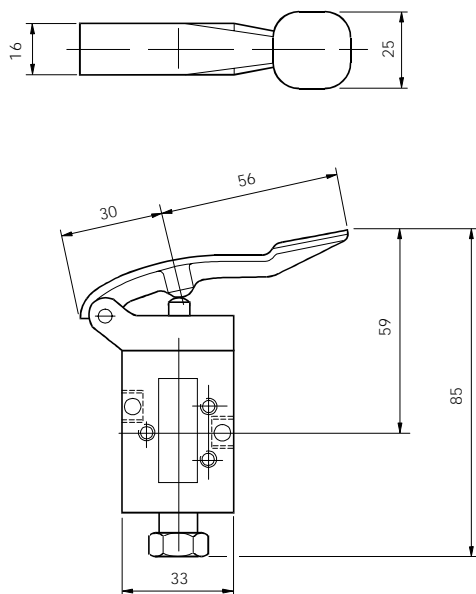

## Foot pedal operated

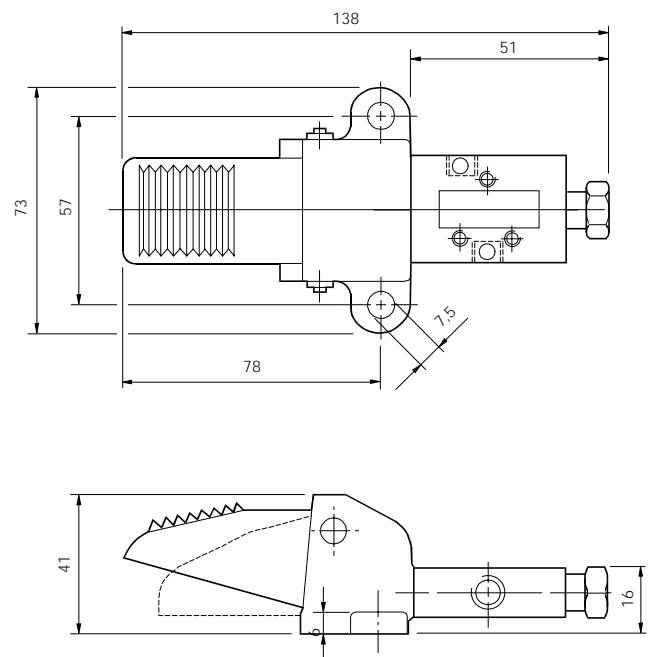

# Facia actuators Ø22mm, G<sup>1</sup>/<sub>8</sub> 3/2 - 5/2

## The system

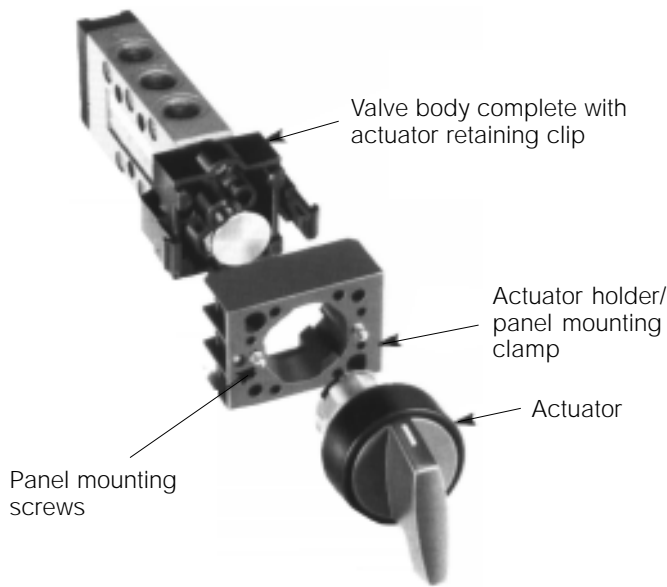

## Dimensions (mm)

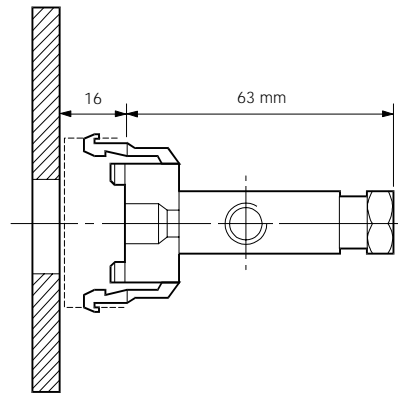

## Basic valve with adaptor

Part no.	Type	Symbol
<b>B43603-100A</b>	3/2	

## Mounting

Assembly is simple; the actuators fit into the holder/panel mounting clamp with bayonet fixing. The panel mounting screws may then be tightened up to the panel as required and the valve body assembly clipped on. No seals or special tools are required, interchanging actuators or valve body assemblies is equally simple.

## Ø22mm

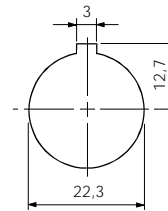

## Latching trust button

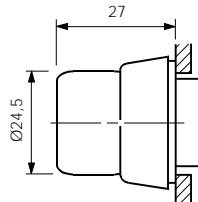

Latching trust button

Colour	
White	<b>33000-100UFS</b>
Blue	<b>33000-100UFXS</b>

## Key switch-latching

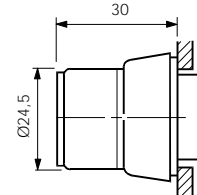

Key switch-latching

Locked position	Withdrawal position	
In or out	Either	<b>33000-100KAS</b>
In	Un-locked	<b>33000-100KBS</b>
Out	Locked	<b>33000-100KCS</b>

## Key switch non-latching

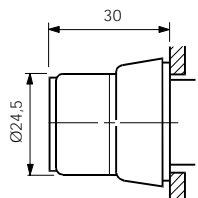

Key switch non-latching

Locked position	Withdrawal position	
Out	Un-locked	<b>33000-100KDS</b>
In	Locked	<b>33000-100KES</b>

## Key switch 'stay-put'

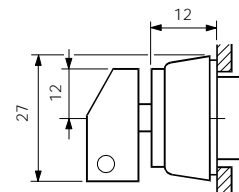

Key switch 'stay-put'

Withdrawal position	
Either	<b>33000-100KFS</b>

# Facia actuators Ø22mm, G<sup>1</sup>/<sub>8</sub> 3/2 - 5/2

## Emergency buttons

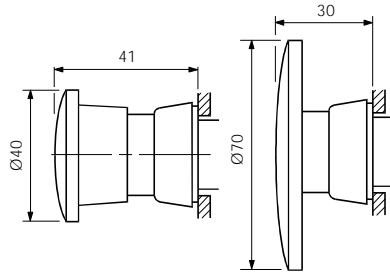

Emergency button

Colour	Type
Red	<b>33000-100BEYS</b> Ø40 Mushroom, key release
Red	<b>33000-100BGYS</b> Ø40 Mushroom latching
Red	<b>33000-100BPYS</b> Raised latching button
Red	<b>33000-100BRYS</b> Ø70 Mushroom latching

## Flush push button

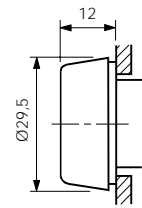

Flush push button

Colour	Type
Yellow	<b>33000-100BATS</b>
Blue	<b>33000-100BAUS</b>
White	<b>33000-100BAWS</b>
Black	<b>33000-100BAXS</b>
Red	<b>33000-100BAYS</b>
Green	<b>33000-100BAZS</b>

## Raised push button

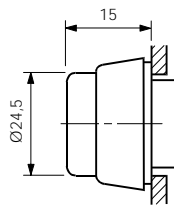

Raised push button

Colour	Type
Yellow	<b>33000-100BBTS</b>
Blue	<b>33000-100BBUS</b>
Black	<b>33000-100BBXS</b>
Red	<b>33000-100BBYS</b>

## Push button with boot

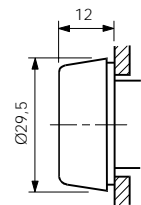

Push button with boot

Colour	Type
Yellow	<b>33000-100BCTS</b>
Blue	<b>33000-100BCUS</b>
White	<b>33000-100BCWS</b>
Black	<b>33000-100BCXS</b>
Red	<b>33000-100BCYS</b>
Green	<b>33000-100BCZS</b>

## Latching and Non latching selector knob

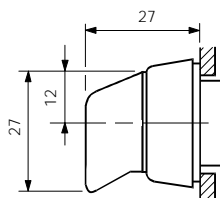

Latching Non latching

Colour	Latching	Non latching
White	<b>33000-100UAWS</b>	<b>33000-100UBWS</b>
Black	<b>33000-100UAXS</b>	<b>33000-100UBXS</b>
Red	<b>33000-100UAYS</b>	<b>33000-100UBYS</b>
Green	<b>33000-100UAZS</b>	<b>33000-100UBZS</b>

## Ø30mm Mushroom button

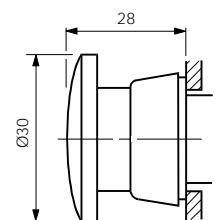

Ø30mm Mushroom button

Colour	Type
White	<b>33000-100BDTS</b>
Black	<b>33000-100BDXS</b>
Red	<b>33000-100BDYS</b>
Green	<b>33000-100BDZS</b>